

# New Equipment Warranty

## Limited Warranty

Sandia Products warrants new equipment against defects in material and workmanship under normal use and service to the original purchaser. Any statutory implied warranties, including any warranty of merchantability or fitness for a particular purpose, are expressly limited to the duration of this written warranty. Sandia Products will not be liable for any other damages, including but not limited to indirect or special consequential damages arising out of or in connection with the furnishing, performance, use or inability to use the machine. This remedy shall be the exclusive remedy of the purchaser. The warranty period is subject to the conditions stated below.

## Lifetime Warranty on Body, 5-Years on Vacuum Motor and all Electrical Parts, 90-Days on Tools and Accessories

Sandia Products warrants the roto-molded body to be free from defects in material and workmanship, under normal use and service for a lifetime. Sandia Products warrants the motor and all electrical components to be free from defects in material and workmanship, under normal use and service for five (5) years from the original date of sale. Parts replaced or repaired under this warranty are warranted for the remainder of the original warranty period. Service labor charges are covered for one (1) year from the date of purchase, when performed by a manufacturer-authorized service provider.

Labor is only provided by authorized service centers. If an authorized service center is not near you, it is the purchaser's responsibility to take their machine to an authorized service center.

Normal wear items such as capacitors, cords, finishes or switches will be warranted for manufacturing defects for ninety (90) days from the purchase date.

All warranties of motors and associated components will be voided: if the machine is serviced by anyone other than an authorized service provider; if the machine is mechanically modified; if the machine is operated when not operating properly; or if the machine is misused or abused.

The warranty starts on the purchase date by the original purchaser from Sandia Products subject to proof of purchase. The Machine Registration Card must be completed and returned immediately at the time of purchase. Registration may also be performed online at: [www.sandiaplastics.com/registration.aspx](http://www.sandiaplastics.com/registration.aspx). If proof of purchase cannot be identified, the warranty start date is ninety (90) days after the inventory stocking date at the distributor's warehouse.



**Ultimate Solutions Corporate Office**  
15571 Container Lane, Huntington Beach, CA 92649  
Phone: 800-983-5834 | Fax: 714-901-8404  
[www.us-group.com](http://www.us-group.com) | [www.sandiaplastics.com](http://www.sandiaplastics.com)

**Make a copy of this card for future reference.**

Copyright © 2015 Ultimate Solutions | Sandia Products. All Rights Reserved.

## SAFETY, OPERATION AND MAINTENANCE MANUAL WITH PARTS LIST

Please read before use!

**1.5 HP, UP TO 150 CFM**

REGISTER  
YOUR  
MACHINE  
ONLINE!



**RAVEN BACKPACK VACUUM**  
6-Quart Backpack Vacuum Series



Available!



Manufactured with  
Pride in the U.S.A.



**ULTIMATE  
SOLUTIONS**  
Together We're Better!

## IMPORTANT INFORMATION AND SAFETY INSTRUCTIONS

Register your Machine Online or Return your Machine Warranty Card!

Serial No: \_\_\_\_\_

Another Innovative  
Product from

**Sandia**  
PRODUCTS

Your Ultimate Choice in  
Profitable Cleaning Performance!



**Dear Valued Client,**

Congratulations on the purchase of your Raven 6-Quart Backpack Vacuum! The world of carpet cleaning is becoming more high-tech and competitive and we strive to provide you with the most innovative products. Our backpack vacuum is yet another example of this, bringing a new dimension to carpet and upholstery cleaning with its cutting-edge features, quality and value.

Please review this manual paying careful attention to the Safety Instructions section. Keep in mind that any unnecessary damage, neglect or abuse of this machine will void your warranty. You can be confident that simple maintenance will ensure that your Backpack Vacuum provides quality performance for many years to come.

If warranty questions arise, please consult your manual or contact your distributor. Should you have any questions regarding maintenance, replacing parts or ordering parts, please call an authorized distributor.

Before you begin using your Backpack Vacuum, thoroughly review the Owner's Manual.

Again, congratulations on the purchase of your Raven 6-Quart Backpack Vacuum!

**Questions or Comments?**

Phone: 714-901-8400  
Toll Free: 800-983-5834  
Fax: 714-901-8404

Ultimate Solutions Corporate Offices:  
15571 Container Lane, Huntington Beach, CA 92649

Visit our website at: [www.sandioplastics.com](http://www.sandioplastics.com)  
Register your machine online at: [www.sandioplastics.com/registration.aspx](http://www.sandioplastics.com/registration.aspx)



**WARRANTY REGISTRATION**

**Please take a moment to register your machine. Fill out the information below and mail back to Sandia Products immediately.**

The warranty starts on the purchase date by the original purchaser subject to proof of purchase. This Machine Registration Card must be completed and returned immediately at the time of purchase. If proof of purchase cannot be identified, the warranty start date is ninety (90) days after the inventory stocking date at the distributor's warehouse.

Your machine may also be registered online at:  
[www.sandioplastics.com/registration.aspx](http://www.sandioplastics.com/registration.aspx)

Machine Model \_\_\_\_\_ Purchase Date \_\_\_\_\_

Motor Type \_\_\_\_\_ Serial No. \_\_\_\_\_

Place of Purchase \_\_\_\_\_

Shipped To \_\_\_\_\_

Your Name \_\_\_\_\_ Phone \_\_\_\_\_

E-mail \_\_\_\_\_ Fax \_\_\_\_\_

Address Line 1 \_\_\_\_\_

Address Line 2 \_\_\_\_\_

City \_\_\_\_\_ State \_\_\_\_\_ Zip \_\_\_\_\_

Comments:

**Mail to:**  
Ultimate Solutions Corporate Offices  
15571 Container Lane  
Huntington Beach, CA 92649

**See reverse side for Warranty Information.  
Make a copy of this card for future reference.**

Copyright © 2015 Ultimate Solutions | Sandia Products. All Rights Reserved.

# 6-QUART RAVEN BACKPACK VACUUM

By Ultimate Solutions | Sandia Products

## Please fill out the following information:

Model No: \_\_\_\_\_

Serial No: \_\_\_\_\_

Distributor Name: \_\_\_\_\_

Distributor Phone No: \_\_\_\_\_

Date of Purchase: \_\_\_\_\_



**The Ultimate Solutions Group**  
Our Family of Companies  
**TOGETHER WE'RE BETTER!**

**Sandia**  
PRODUCTS

Your Ultimate Choice in  
Profitable Cleaning Performance!

**Ultimate Carpet Solutions**  
[www.sandiaplastics.com](http://www.sandiaplastics.com)



**Ultimate Hard Floor Solutions**  
[www.mercuryfloormachines.com](http://www.mercuryfloormachines.com)



**Ultimate Cleaning Solutions**  
[www.ultimatesolutionsinc.net](http://www.ultimatesolutionsinc.net)



## Table of Contents

Returned Material Authorization (RMA) Procedure .....	3
New Equipment Warranty .....	4
1.0 Safety Instructions .....	5
2.0 Grounding Instructions .....	6
3.0 Care of your Backpack Vacuum Cleaner .....	7
4.0 Operation and Assembly Instructions .....	8
5.0 Trouble Shooting Guide .....	10
6.0 Machine Schematic Drawing .....	11
7.0 Machine Parts List .....	12
8.0 5-Piece Tool Kit .....	13

## Returned Material Authorization (RMA) Procedure

Original purchaser (distributor/service center) must contact the manufacturer to follow correct RMA/warranty procedures. Must include a copy of RMA Sheet enclosed in the box with returned item. No returns shall be authorized unless proper RMA procedures are followed. It is the responsibility of the distributor to repair the client's equipment as soon as possible. Labor is only provided by authorized service centers. If an authorized service center is not near you, it is the purchaser's responsibility to take their machine to an authorized service center.

Client must contact the distributor prior to working on or changing out any parts, etc. Manufacturer must issue an RMA Sheet containing approved labor time and replacement parts. Do not send parts or equipment back to manufacturer without an RMA number and approval. No labor will be paid for, nor part costs paid for or reimbursed that have not been previously approved by the manufacturer. All warranty work must be approved and authorized to qualify and appropriate warranty procedures must be followed.

## New Equipment Warranty

Lifetime on body, 5-years on motor and on all electrical components, 90-days on tools and accessories.

### Warranty Policy

All equipment is inspected and tested before shipping from the manufacturer. All parts are warranted to be new and free from defects in workmanship and material, under normal use to the original retail purchaser. This warranty limits manufacturer's liability for defects in workmanship or materials for replacement of defective parts only. The manufacturer accepts no liability for incidental or consequential damages arisen from the use of any equipment, defective or not. This warranty is in lieu of all expressed or implied warranties and is extended only to the original retail purchaser. Manufacturer sales and service representatives are not authorized to waive or alter the terms of this warranty, or to increase the obligations of the manufacturer under the warranty. Parts replaced or repaired under this warranty are warranted for the remainder of the original warranty period.

Labor is only provided by authorized service centers. If an authorized service center is not near you, it is the purchaser's responsibility to take their machine to an authorized service center.

The manufacturer covers up to one (1) year (365 days) of service labor at the manufacturer's calculated hourly labor rate/repair time when performed by a manufacturer-authorized service provider. Ultimately, labor reimbursement costs are at the discretion of the manufacturer. At no time is the manufacturer responsible for travel time to complete on-call repairs. After one (1) year, the original retail purchaser is responsible for all labor costs with no manufacturer reimbursement.

The original purchaser must contact the manufacturer to follow correct RMA/warranty procedures. They must include a copy of the RMA Sheet enclosed in the box with the returned item. No returns shall be authorized unless the proper RMA procedures are followed. It is the responsibility of the distributor to repair the client's equipment as soon as possible.

The manufacturer charges a 25% restocking fee for any items that are being returned to stock. Items must be new, unused, free of damage and are only good for up to 30 days. After 30 days, the manufacturer does not accept the return of any items for a store credit.

Authorized warranty replacement parts need to come directly from the manufacturer. Any use of any other parts will void warranty. The manufacturer does not reimburse for parts used by client that were not supplied directly for the machine under warranty.

The client must contact the manufacturer prior to working on or changing out of any parts, etc. The manufacturer must issue an RMA Sheet containing approved labor time and replacement parts. Do not send parts or equipment back to the manufacturer without an RMA Number and approval. No labor will be paid for, nor parts cost paid for or reimbursed, that have not previously been approved by the manufacturer. All warranty work must be approved and authorized to qualify, and appropriate warranty procedures must be followed.

The warranty starts on the purchase date by the original purchaser from an authorized distributor, subject to proof of purchase. The Machine Registration Form must be completed and sent to the original manufacturer at the time of purchase. If proof of purchase cannot be identified, the warranty start date is ninety (90) days after the date of sale to an authorized distributor.

Register your machine online at: [www.sandioplastics.com/registration.aspx](http://www.sandioplastics.com/registration.aspx)

## 8.0 5-Piece Standard Tool Kit

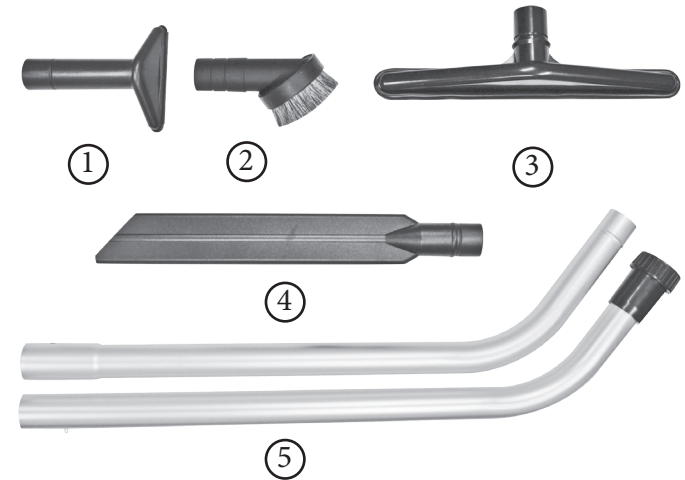

Drawing No.	Item No.	Description	Quantity
1	10-0031	5" Upholstery Tool	1.00
2	10-0037	3" Round Dust Brush	1.00
3	10-0032	14" Scalloped Floor Tool	1.00
4	10-0033	17" Crevice Tool	1.00
5	10-0029	2-Piece, 2-Bend Button Lock Wand	1.00

\* Only Included with Select Models



## 7.0 Machine Parts List

Drawing No.	Item No.	Description	Quantity
1	10-007-6	6-Quart Cloth Bag for 6-Quart Backpack	1.00
2A	10-0197	6-Quart Paper Bags (10 Pack)	0.10
2B	10-0197-HEPA	6-Quart HEPA Paper Bags (10 Pack)	0.10
3	BP-6-L-USI BLUE	6-Quart Backpack Lid - USI Blue	1.00
4	10-0155	Hose Cuff Straight	1.00
5	10-0024	1-1/2" Black Vacuum Hose	1.00
6	10-0195	Swivel Cuff	1.00
7A	10-0008-B	Dome Filter with Bag Support	1.00
7B	10-0219-6	Complete 6-Quart HEPA Filter (HEPA Model Only)	1.00
8A	10-0013	Super Motor (Super, HEPA, Aviation Models)	1.00
8B	10-0012	Whisper Motor (Whisper Models Only)	1.00
8C	10-0346	D.P. Motor (Avenger Models Only)	1.00
9	10-0199	Vacuum Motor Gasket	1.00
10	10-0023	Shoulder and Waist Belt Washer	4.00
11	10-0022	Shoulder and Waist Belt Screw	4.00
12	10-0021	Shoulder and Waist Belt	1.00
13	10-0020	Cushioned Back Pad	1.00
14	BP-6-T-USI BLUE	6-Quart Backpack Tank - USI BLUE	1.00
15	10-0015	1/4" Flat Washer	4.00
16	10-0014	Motor Screw	4.00
17	BP-6-B-BLKGRAN	6-Quart Backpack Base - Black Granite	1.00
18	10-0016-6	6-Quart Deflector Plate	1.00
19	10-0017	Deflector Plate Screw	3.00
20	10-0017	Sound Dampening Band	1.00
21	10-0018	6-Quart Dual Cell Noise Filter	1.00
22	10-0019-6	Screw for Well Nut	1.00
23	10-0070	Well Nut for Cord Lock	1.00
24	10-0027-A	Strain Relief Nut	1.00
25	10-0027	Strain Relief	1.00
26	10-0026	17" Power Cord (Cord Only)	1.00
27	10-0028	50-Foot Electrical Cord	1.00
28	10-0025	On/Off Switch	1.00

## 1.0 Safety Instructions

READ THIS MANUAL BEFORE OPERATING MACHINERY. KNOW THE PROPER SET-UP, OPERATION, CORRECT APPLICATIONS AND THE LIMITATIONS OF THIS EQUIPMENT **BEFORE** USE.

This backpack vacuum will afford you many years of trouble-free operating satisfaction, provided it is given the proper care. All parts have passed rigid quality control standards throughout the assembly process. Prior to packaging, your backpack vacuum was again inspected for assurance of flawless operation.

This backpack vacuum is protectively packed to prevent damage in shipment. We recommend that upon delivery, unpack the unit and inspect it for any possible damage. Only a visual inspection will reveal damage that may have occurred.

If damage is discovered, immediately notify the transportation company that delivered your vacuum. As a shipper, we are unable to report any claim for damage. You must originate any claim within five (5) days.

This manual is for your protection and information. Please read carefully since failure to follow precautions could result in discomfort or injury.

### Reduce the Risk of Fire, Electric Shock or Injury

**DO NOT USE ON WET SURFACES OR EXPOSE TO RAIN. STORE INDOORS.**

Use only as described in this safety operating manual. Use only the manufacturer's recommended attachments, accessories, replacement parts and filters. Replace damaged or worn parts immediately with genuine, original equipment parts to maintain safety and to protect your limited warranty.

Always turn OFF the vacuum before connecting, disconnecting or working on the vacuum. This vacuum must be connected to a properly grounded outlet only (see grounding instructions). The extension cord provided with this unit is 50-foot, 16/3-gauge wire and **MUST** be used with this unit to ensure grounding protection. Turn off all controls before unplugging. Make sure the on/off switch is in the off position. This is not a toy. Close attention is necessary when used around or near children. Use extra care when cleaning on stairs.

**NOTE:** when using the vacuum with a powerhead tool and connection, always turn off the vacuum and nozzle tool before connecting or disconnecting either the hose or power nozzle. Depending on your vacuum model, the hose may contain electrical wires.

- **DO NOT** leave the vacuum when plugged in. Unplug it from the outlet when not in use and before servicing.
- **DO NOT** use this vacuum with a damaged cord or plug. If the vacuum is not working as it should because it has been dropped, damaged, left outdoors or dropped into water, etc., contact an authorized service center.
- **DO NOT** unplug the vacuum by pulling the cord. To unplug, grasp the plug, not the cord. **DO NOT** pull or carry by the cord, use the cord as a handle, close a door on the cord, or pull the cord around sharp edges or corners. Keep the cord away from heated surfaces.
- **DO NOT** overstretch the safety power cord between the vacuum and the electrical outlet in the wall.

## 1.0 Safety Instructions Continued

### Reduce the Risk of Fire, Electric Shock or Injury.

- DO NOT tie an extension cord to the pigtail cord. This will damage the cord and will VOID your warranty.
- DO NOT handle the plug of the vacuum with wet hands.
- DO NOT vacuum up any liquids. This vacuum is for dry use only!
- DO NOT expose to rain or use on wet surfaces, to avoid electric shock. Store indoors.
- DO NOT pick up anything that is burning or smoking such as cigarettes, matches or hot ashes.
- DO NOT use the vacuum to pick up flammable or combustible liquids such as gasoline or use in areas where they may be present.
- DO NOT use where oxygen or anesthetics are used.
- DO NOT put objects into openings or use with any openings blocked. Keep free of dust, lint, hair and anything that may reduce air flow. Keep hair, loose clothing, fingers, and all body parts away from openings and moving parts to ensure safe operation.
- DO NOT use without the proper cloth filtration bag, paper filter bag and other filters in place. Failure to do so, will VOID your warranty.
- DO NOT use if any hoses or nozzles are damaged, cut or punctured.
- DO NOT lubricate the motor. If the motor is lubricated, this will VOID your warranty.

## 2.0 Grounding Instructions

### DANGER: IMPROPER GROUNDING METHOD CAN RESULT IN A RISK OF ELECTRIC SHOCK!

Electrical equipment must be grounded. Improper connection of the equipment grounding conductor can result in a risk of electric shock. If the equipment should malfunction or breakdown, grounding provides a path of least resistance for electrical current to reduce the risk of electric shock.

This vacuum is equipped with a cord containing a grounding conductor and grounding plug. The plug must be inserted into an appropriate outlet that is properly installed and grounded in accordance with all local codes and ordinances.

Check with a qualified electrician or service person if you are in doubt as to whether the outlet is properly grounded. DO NOT modify the plug provided with the equipment. If it will not fit into the outlet, have a proper outlet installed by a qualified electrician.

If repair or replacement of the cord or plug is necessary, DO NOT connect the grounded wire to a flat bed terminal. The wire with insulation having an outer surface that is green with or without yellow stripes is the grounding wire.

**NOTE:** In Canada, the use of a temporary adapter is not permitted by the Canadian Electrical Code.

## 6.0 Machine Schematic Drawing

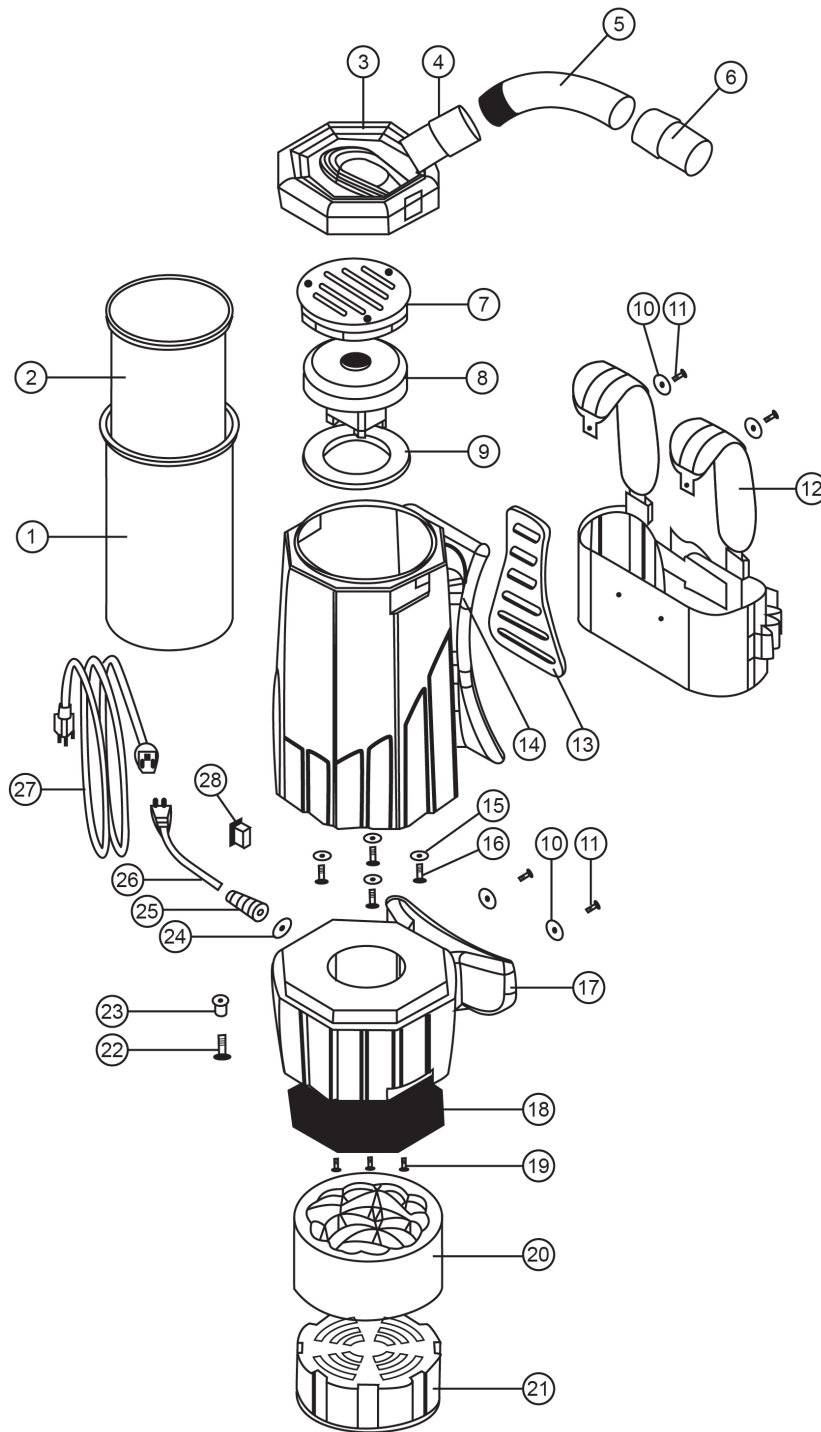

## 5.0 Troubleshooting Guide

**CAUTION:** Always disconnect power cord before servicing vacuum.

**WARNING:** Repairs should only be performed by an authorized service center. Failure to do so will VOID warranty.

### PROBLEM: Loss of vacuum

CAUSE	SOLUTION
Lid is damaged	Inspect and replace if needed
Faulty vacuum motor	Call manufacturer or authorized service center
Full paper bag filter	Replace paper filter bag
Clogged hose or wand	Remove obstruction
Loose or broken fan	Call manufacturer or authorized service center

### PROBLEM: Motor is not running

CAUSE	SOLUTION
Faulty on/off switch	Call manufacturer or authorized service center
Power cord defective	Call manufacturer or authorized service center
Loose connection or wiring	Call manufacturer or authorized service center
Motor defective	Call manufacturer or authorized service center
Blown fuse or tripped circuit breaker	Replace fuse or reset circuit breaker

### PROBLEM: Dust blowing from vacuum when running

CAUSE	SOLUTION
Full paper bag	Replace filter bag
Paper filter bag not installed properly	Reinstall or replace paper filter bag properly
Cloth filter bag is dirty	Clean cloth filter bag by shaking and dusting
Cloth or paper filter bag is torn	Replace - failure to use a

All filters must be used at all times. Failure to do so will VOID your warranty.

## 2.0 Grounding Instructions Continued

This electric equipment is for use on a normal 120 volt circuit. It has a grounded plug that looks like the plug illustrated in (Fig A). A temporary adapter, such as illustrated in (Fig B and C), may be used to connect this plug into a two-pole receptacle, as shown in (Fig B), if a properly grounded outlet is not available.

The temporary adapter should be used only until a properly grounded outlet (Fig A) can be installed by a qualified electrician. The green color rigid ear lug or the like extending from the adapter must be connected to a permanent ground such as a properly grounded outlet box cover. Whenever the adapter is used, it must be held in place by a metal screw.

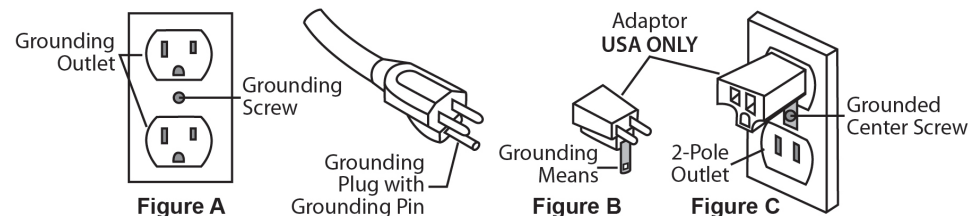

## 3.0 Care of your Backpack Vacuum

Treat your vacuum as you would any other high grade, precision made product. Dropping, unreasonable bumping across thresholds and other misuses may result in a damaged unit which will not be covered under warranty.

When not in use, the power cord should be wrapped around the molded-in cord wrap and stored in a dry area. After each use, wipe the vacuum body, accessories and power cord with a slightly damp cloth.

**WARNING: DO NOT use vacuum without the proper cloth filtration bag, paper filter bag and other filters in place. Failure to do so, will VOID your warranty.**

If using this vacuum in a paint, sawdust or drywall environment, you must dispose of the paper filter bag and the shakeout cloth filter bag after each use. Failure to do so will cause severe damage to your vacuum and VOID your warranty. Dispose of the paper filter bag in a fireproof container. The combination of urethane and wood, may result in a combustion.

## 4.0 Operation and Assembly Instructions

DRY PREPARATION AND OPERATION ONLY! DO NOT ASSEMBLE OR USE ON WET SURFACES.

This vacuum is equipped with an air-thru motor and is designed for dry pickup only. Ensure assembly and use of this equipment is only conducted in a dry environment. To begin, unpack the carton and remove the vacuum and attachments (if purchased with tools). Always exercise caution when handling the vacuum. Dropping the vacuum could cause permanent damage to the internal components.

### Getting Started:

1. Make sure the on/off switch is in the OFF position.
2. Remove the lid and check to ensure you have both a cloth filter bag and paper filter bag in place. Place the lid back onto the vacuum body, tightening securely. Both bags must be used at all times. Any damage resulting from the lack of using both bags will VOID your warranty.
3. Wrap the safety power cord around the molded-in cord wrap on the side of the unit. Do not tie or loop the pigtail cord with the extension cord.
4. Loosen the shoulder and waist belt straps and slide vacuum onto your back.
5. Connect and tighten the waist belt making sure the majority of the weight is on your hips and not your shoulders.
6. Adjust the shoulder straps for comfort.
7. Connect the sternum strap for added support and ideal fit.
8. Plug the vacuum into a properly grounded outlet.
9. Turn the unit to the ON position and proceed with vacuuming.
10. Always store vacuum, safety power cord and tools in a cool, dry place indoors.

**NOTE:** The weight of the vacuum should be distributed on your hips. Adjust any strap as needed for your custom fit.

### Changing the Paper Filter Bag:

1. Unscrew lid and lift lid off of the body.
2. Remove the full paper bag from the tank and dispose of properly in a fireproof container.
3. Take a new paper filter bag and set inside cloth filter bag, expanding it to the sides of the cloth filter bag.
4. Place lid back onto the vacuum body, tightening securely.

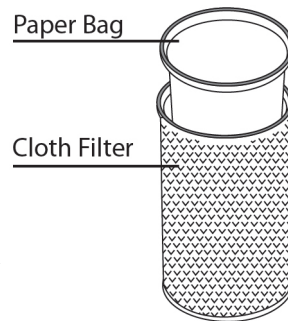

### Maintaining the Cloth Filter:

The cloth filter should be inspected and cleaned each time you empty the tank. DO NOT wash the cloth filter. It could cause shrinkage of the cloth and damage to the gasket. Simply shake off any dust or loose particles and brush the exposed surface with a soft bristle brush.

## 4.0 Operation and Assembly Instructions Continued

### Maintaining the HEPA Cloth Filter:

When the white disk inside your dome filter is discolored, replace it with a new HEPA filter with bag support. Replacement time frame of the HEPA filter depends on the frequency and application of use. For best results, replace every six (6) months.

**IMPORTANT:** Following the above instructions is critical in prolonging the life of your vacuum. All filters must be used at all times. Failure to do so will VOID your warranty.

### Assembling Attachments:

The vacuum comes assembled, but you will need to install the hose to the wand and the wand to the attachment.

#### Wand Assembly (for 2-Piece Wand Only):

- Align the button lock of the upper wand section with the opening for the button lock in the lower wand section.
- Push the sections together until the button lock slides into place and the lock is secured.

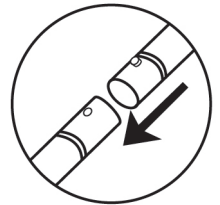

#### To Connect Wand to Hose:

- Insert the tapered end of the wand into the swivel cuff at the end of the hose.

#### To Connect Wand to Attachments:

- Turn wand nut counterclockwise approximately four (4) complete turns.
- Insert the tool into the wand and coupling.
- While holding the tool in place, turn nut clockwise until wand nut is fully locked.

