

User Manual



ESCAPE

Model: ETM-LX-115
Electric Truckmount

REV. 7/30/18

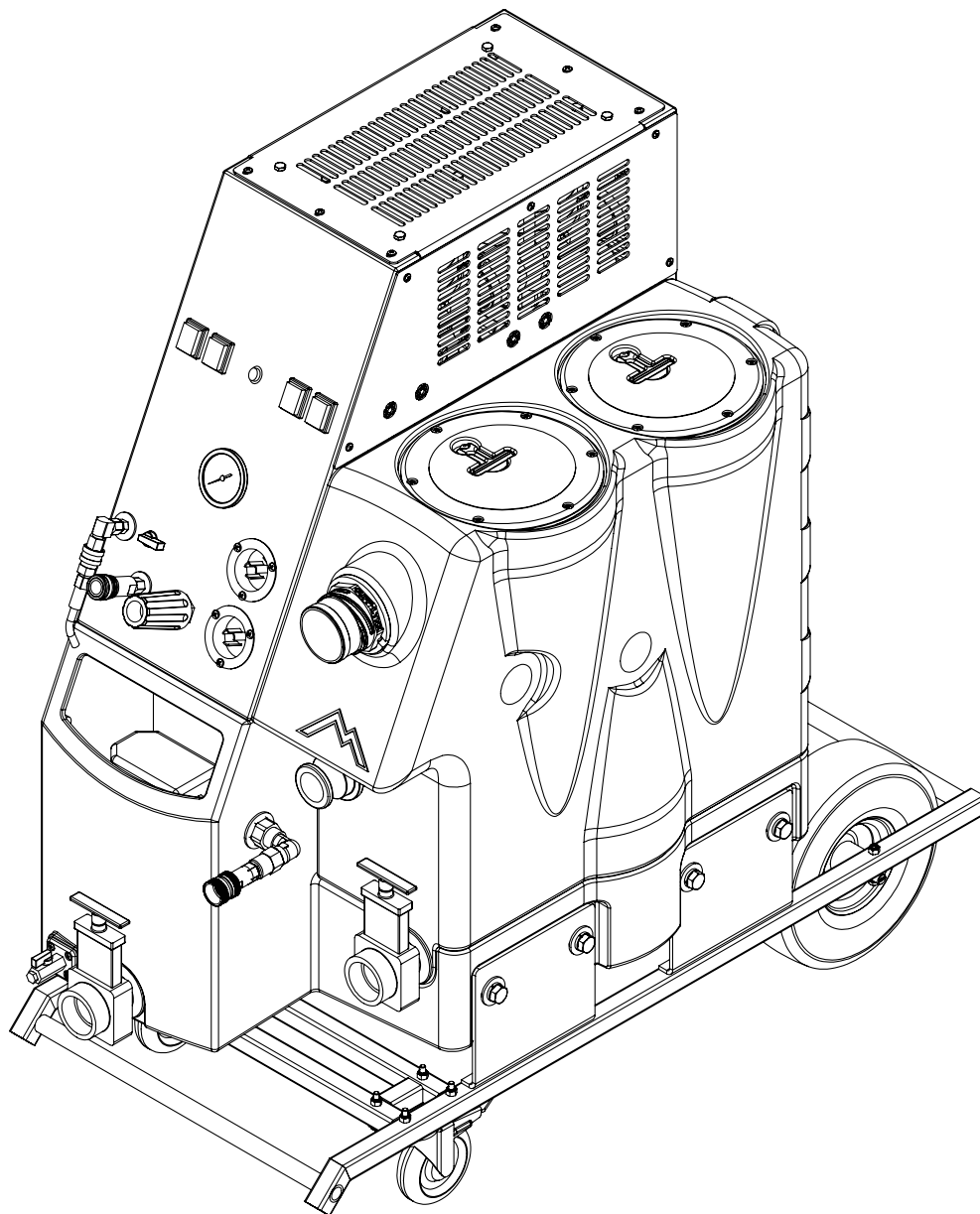

Dear Customer:

Congratulations on the purchase of your new Escape™ Electric Truckmount.

As technology continues to develop you can work confidently knowing that both Mytee Products and its employees are equally dedicated to developing with the industry and its advances.

Like any other piece of machinery or technology, the ETM also requires the proper maintenance and care to keep the product working over extended use. Neglecting your machine, abusing it or not operating it properly can void its warranty and prevent the machine from performing to the quality and standard you'd expect out of the Mytee Products line.

If you have any warranty concerns or questions, please review this manual thoroughly or do not hesitate to contact your distributor. If there are questions regarding maintenance, replacement, or ordering parts please contact an authorized Mytee Products Service Center. To see an updated list please visit our website at <http://www.mytee.com/support/service-centers>.

Before using your Mytee product, please read this manual thoroughly.

*Sincerely,
Mytee Customer Care Dept.*

	IMPORTANT SAFETY INFORMATION	4
1	AT A GLANCE	6
	1.1 - Technical Specifications.....	6
	1.2 - Included with the Escape™.....	6
	1.3 - Escape™ Front View.....	7
	1.4 - Escape™ Rear View.....	8
	1.5 - Switch Plate.....	9
2	MACHINE OPERATION	10
	2.1 - Powering the Escape™.....	10
	2.2 - Connecting Hoses & Cleaning Tools.....	11
	2.3 - Using the Auto Fill & Auto Pump-Out Features.....	11
	2.4 - Emptying the Solution & Recovery Tanks.....	11
	2.5 - Preparing the Escape™ for Cold Weather.....	12
3	MACHINE MAINTENANCE	13
	3.1 - Filter Maintenance.....	13
	3.2 - Float Maintenance.....	13
	3.3 - System Maintainer.....	13
4	ACCESSORIES FOR YOUR ESCAPE™	15
5	TROUBLESHOOTING	17

IMPORTANT SAFETY INFORMATION

Grounding Instructions

This machine must be grounded. If it should malfunction or breakdown, grounding provides a path of least resistance for electrical shock. This machine is equipped with a cord having an equipment-grounding conductor and grounding plug. The plug must be plugged into an appropriate outlet that is properly installed in accordance with all local code and ordinances. Do not remove ground pin; if missing, replace plug before use.



Improper installation of the equipment-grounding conductor can result in a risk of electric shock. Be sure to check with a qualified electrician or service person if you are in doubt as to whether the outlet is properly grounded. If the plug will not fit in the outlet do not modify either the plug nor the machine's cord, instead have a proper outlet installed by a qualified technician.

This machine is for use on a nominal 120-volt circuit and with a grounding plug similar to the one in Figure 1 below. If a proper outlet is not available, follow the illustrations of Figure 2 & 3 to install a temporary-grounding plug. This temporary work-around should be used only until a proper outlet (Figure 1) can be installed by a qualified electrician. When and if this type of adapter is employed, screw the adapter's extended tab into place with a metal screw. However, grounding adapters are not approved for use in Canada.

Again, be sure to check the grounding pin for damages and replace if necessary.

The Green, or Green-Yellow, wire in the cord is the grounding wire. When replacing a plug, this wire must be attached to only the grounding pin.

DO NOT use extension cords.

Please Note for America use only.

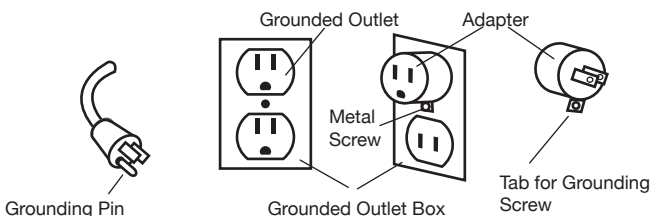

Figure 1

Figure 2

Figure 3

Parts and Service

Please contact a Mytee service personnel or Mytee authorized Service Center using Mytee original replacement parts and accessories for repairs are needing to be performed. When and if calling Mytee for support, please have your Model and Serial Number available for faster assistance.

Name Plate

The Model and Serial Number are located on the lower half of the back of the machine near the power plugs and will be required for ordering replacement parts. You can use the space provided on the front of this manual to note down both for future referencing.

Unpacking the Machine

When your new machine is delivered, please carefully inspect both the shipping carton and the machine for damages. If damage is evident, save both the shipping carton and machine so that the delivering carrier can inspect it. Contact the carrier immediately to file a freight claim if there has been any damage.

Caution and Warnings

Symbols

Mytee uses the symbols below to signal potentially dangerous conditions. Always read this information carefully and take the necessary steps to protect personnel and property.



DANGER

Is used to warn of immediate hazards that will cause severe personal injury or death.



WARNING

Is used to call attention to a situation that could cause severe personal injury.



CAUTION

Is used to call attention to a situation that could cause minor personal injury or damage to the machine or other property. When using an electrical appliance, basic precautions should always be followed, including the following: Read all instructions before using this machine. This

product is intended for commercial use only.

To reduce the risk of fire, electrical shock, or injury:

1. Read all instructions before using equipment.
2. Use only as described in this manual. Use only manufacturer's recommended attachments.
3. Always unplug power cord from electrical outlet before attempting any adjustments or repairs.
4. Do not unplug by pulling on cord. To unplug, grasp the plug, not the cord.
5. Do not pull or carry by cord. Do not close a door on cord or pull cord around sharp edges or corners.
6. Do not run appliance over cord. Keep cord away from heated surfaces.
7. Do not use with damaged cord or plug. If cord is damaged, repair immediately.
8. Do not use outdoors or on wet surfaces and or standing water.
9. Always unplug or disconnect the appliance from power supply when not in use.
10. Do not allow to be used as a toy. Close attention is necessary when used by or near children.
11. Do not use in areas where flammable or combustible material may be present.
12. Do not leave the unit exposed to harsh weather elements. Temperatures below freezing may damage components and void warranty.
13. Use only the appropriate handles to move and lift unit. Do not use any other parts of this machine for this purpose.
14. Keep hair, loose clothing, fingers, and all parts of the body away from all openings and moving parts.
15. Use extra care when using on stairs.
16. To reduce the risk of fire or electric shock, do not use this machine with a solid-state speed control device.
17. The voltage and frequency indicated on the name plate must correspond to the wall receptacle supply voltage.
18. When cleaning and servicing the machine, local or

national regulations may apply to the safe disposal of liquids which may contain: chemicals, grease, oil, acid, alkalines, or other dangerous liquids.

19. Do not leave operating unattended.

1 - AT A GLANCE

1.1 - Technical Specifications

Solution Tank	12 Gallons
Recovery Tank	12 Gallons
Vacuum	Dual Mytee® Hybrid Ametek vacuum motors
CFM	225
Water Lift	182"
Pump PSI	500
Pump GPM	1.5
Pump-Out GPM	35
Power Consumption	Cord one: 19 amps @ 115V 60Hz Cord two: 18 amps @ 115V 60Hz
Machine Weight	200 lbs.
Machine Dimensions	Without cart: 32" x 21.25" x 36" With cart: 43" x 21.25" x 44.25"
Power Cord	Dual twist-lock 50' 12/3

1.2 - Included with the Escape™

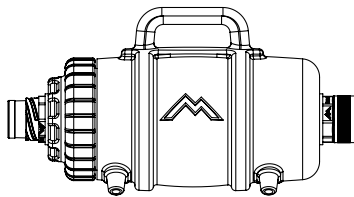

F200 Lint Hog™ In-Line Filter

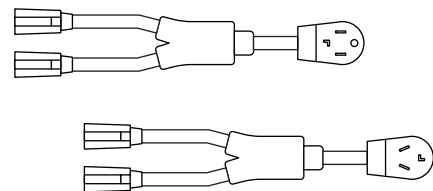

5003 3-Prong Dryer Adapter & 5004 4-Prong Dryer Adapter

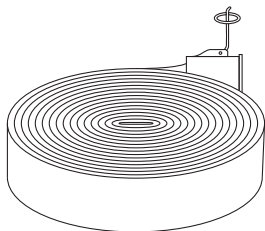

AH121 50' Layflat Pump-Out Hose

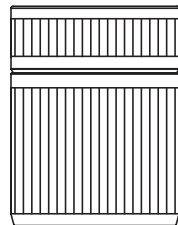

H107 2.5" Swivel Cuff-Lynx™

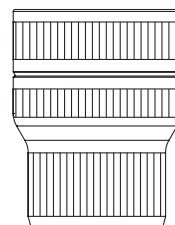

H106 2.5" x 2" Swivel Cuff-Lynx™ Reducer

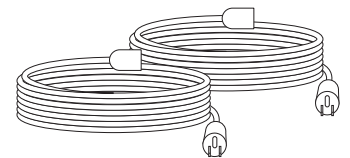

Two 50' Twist-Lock Power Cords

1.3 - Escape™ Front View

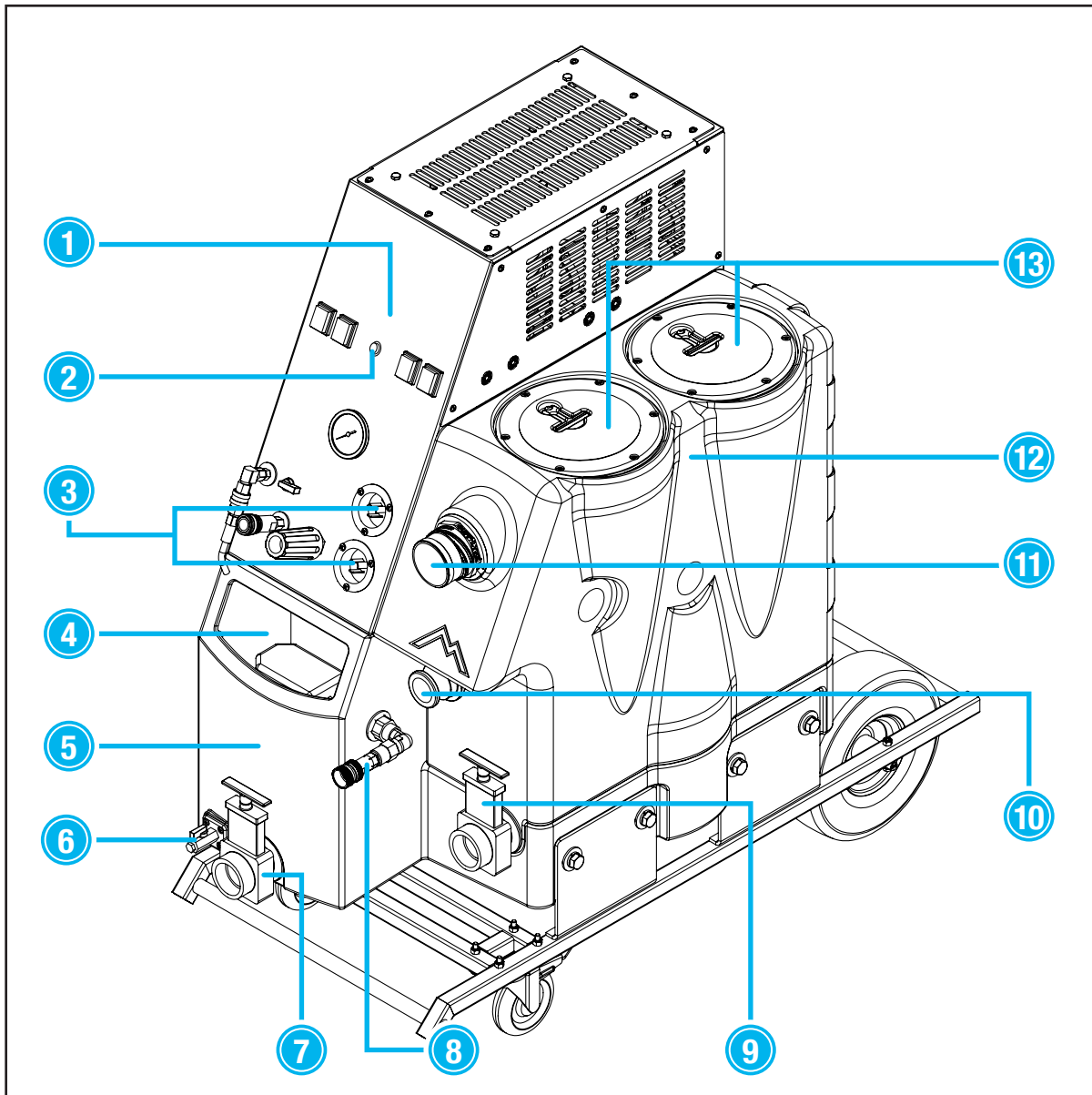

- | | |
|--|---|
| <ul style="list-style-type: none"> 1. Switch Plate 2. Dual Circuit Indicator Light 3. Electrical Power Ports 4. Solution Tank Opening for Bucket Fill 5. 12 Gallon Solution Tank 6. Winterizing Pump Drain 7. Solution Tank Drain Valve | <ul style="list-style-type: none"> 8. Auto Fill 9. Recovery Tank Drain Valve 10. Pump-Out Cam-Lock Hose Connection 11. 2" Male Cuff-Lynx™ Vacuum Hose Connection 12. 12 Gallon Recovery Tank 13. Recovery Tank Lids |
|--|---|

1.4 - Escape™ Rear View

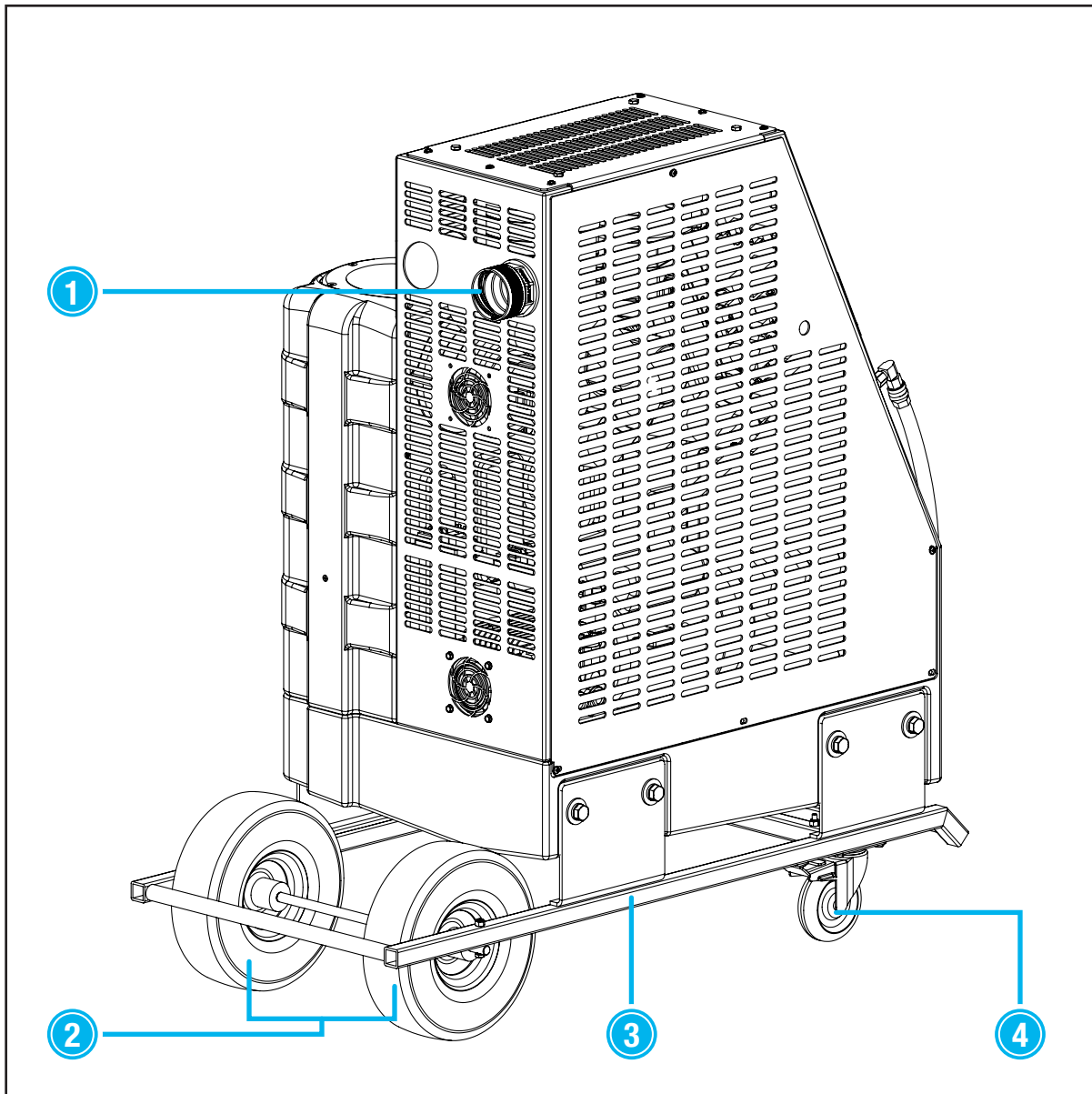

1. Rear Vacuum Exhaust
2. 10" Foan-Filled Wheels
3. Transport Cart
4. 4" Locking Front Casters

1.5 - Switch Plate

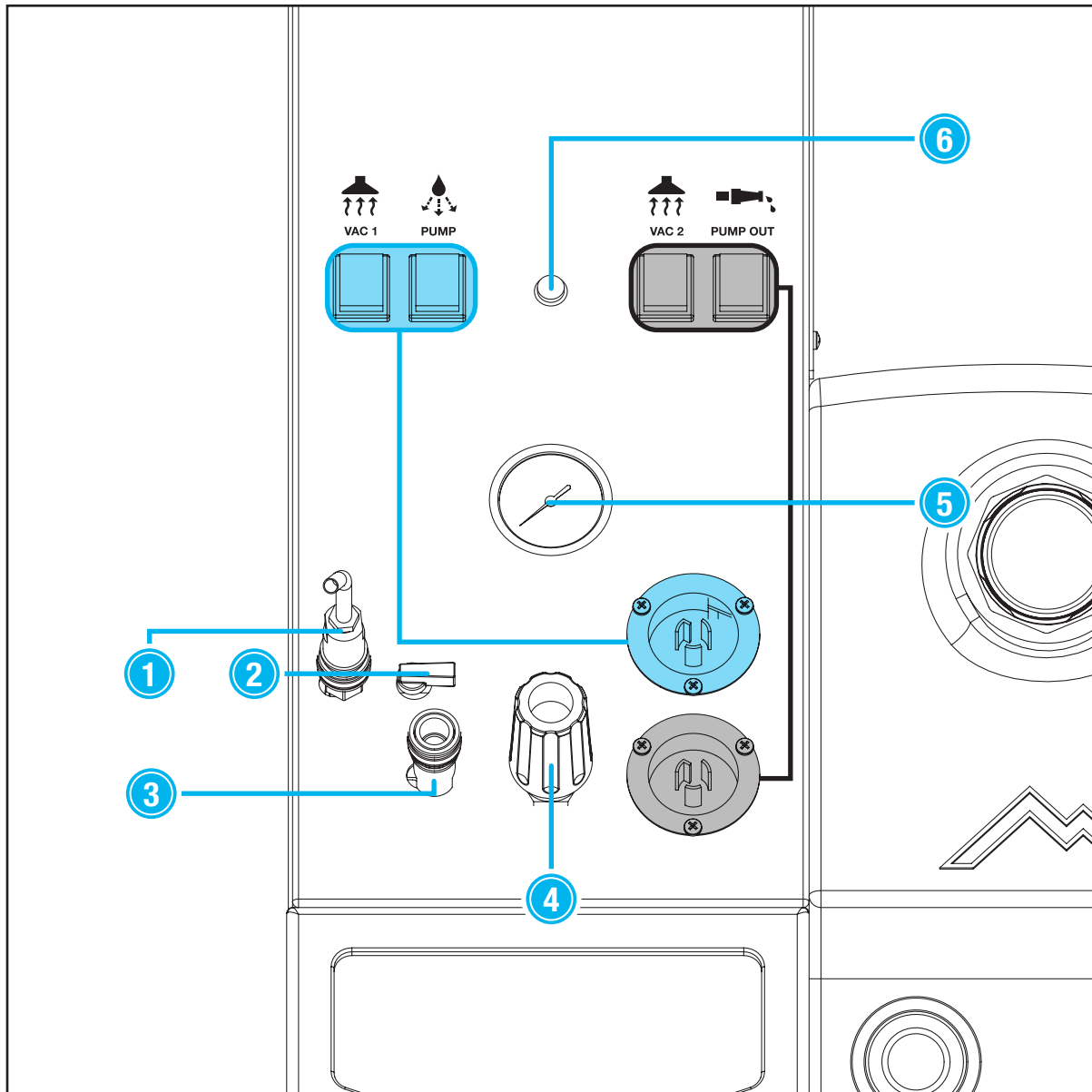

1. Wash Out Hose

Use to wash out the recovery tank after use.

2. RUN/PRIME Valve

Set to the PRIME position to prime the pump and use the wash out hose. Set to the RUN position when ready to clean.

3. Solution Hose Connection

Connect the solution line from the cleaning tool here.

4. Pressure Regulator

Regulates the pressure (PSI) of solution output.

5. Pressure Gauge

Displays the current pressure the solution pump is set to. Measured in PSI.

6. Dual Circuit Indicator Light

Lights up when power cords are plugged into two separate 115V, 20 amp circuits.

2 - MACHINE OPERATION

2.1 - Powering the Escape™

The Escape™ Truckmount can be powered by a few different methods whether in a van or in a home or office.

Method 1 - Two 115V 20 amp circuits.

The Escape™ can be powered off of two separate 115V 20 amp circuits.

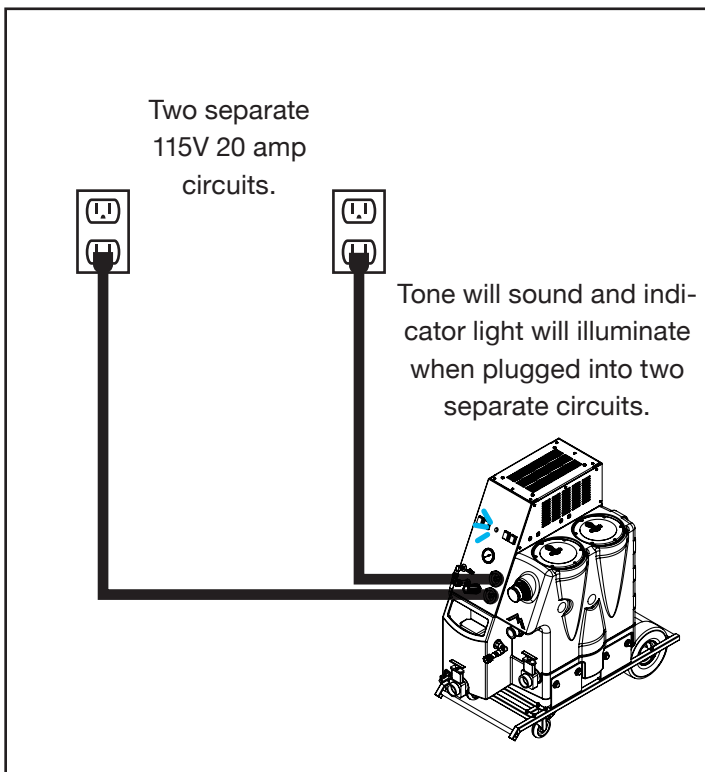

Method 2 - 3-prong or 4-prong dryer outlet.

All Escape™ features can be powered using one of either the 5003 3-prong or 5004 4-prong adapters plugged into a 230V dryer outlet.

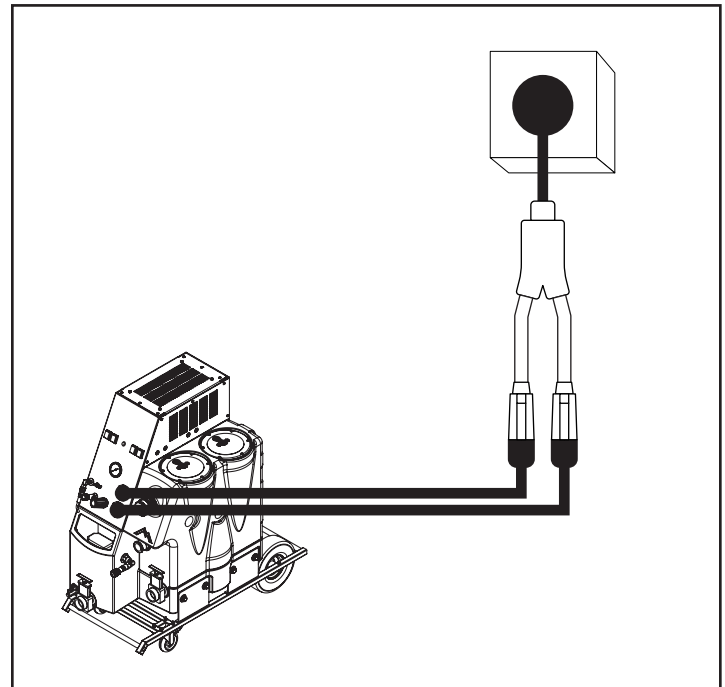

Method 3 - Powering in a van with a generator.

When using the Escape™ in a van or truck, you will need a generator to power it. You can use either a generator that runs off your van or truck's engine or one that has its own motor and fuel tank.

Mytee recommends the use of a 10,000 watt generator with this unit. This will supply ample power for the ETM.

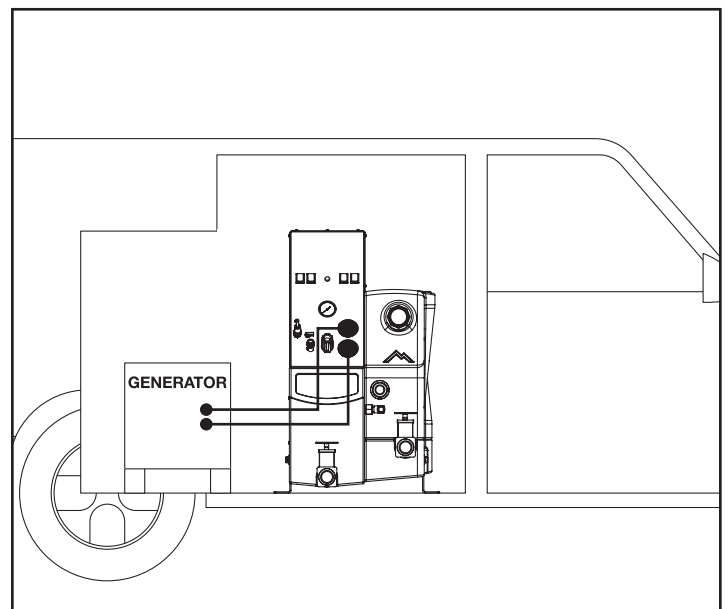

However, the Escape™ can be run on some 6,000 watt generators, depending on the manufacturer. Generators are rated differently, so if using 6,000 watt generator the rating must represent continuous running watts, not peak watts.

In any case, check with the generator manufacturer to ensure the unit can provide 40 amps at 115 volts continuously.

Dual Circuit Indicator Light & Tone

The ETM-LX-115 is equipped with a Dual Circuit Indicator Light & Tone which activates when the unit is plugged into two separate 115V, 20 amp circuits. When the light and tone activate, the unit is properly powered and can be switched on. ♦

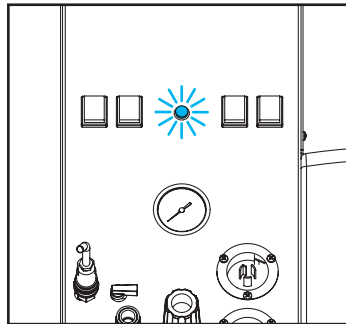

2.2 - Connecting Hoses & Cleaning Tools

Vacuum & Solution Hoses

The Escape™ features a 2.5" Cuff-Lynx™ vacuum hose connection as well as a standard 1/4" quick disconnect fitting for solution hoses.

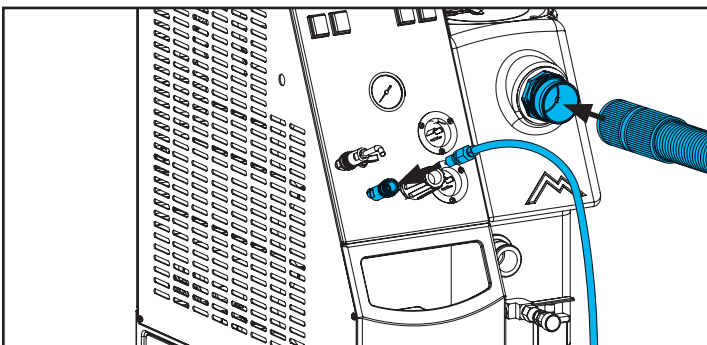

Auto-Fill & Auto Pump-Out Hoses

The Escape™ comes packaged with a 50' lay-flat pump-out hose that connects via a cam-lock fitting. To use the auto-fill feature, simply connect a standard garden hose to the fitting on the front of the unit. For more information on the pump-out and auto-fill features, see section 2.4. ♦

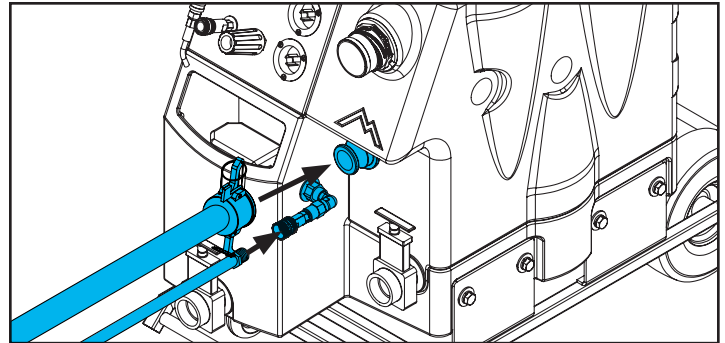

2.3 - Using the Auto-Fill & Auto Pump-Out Features

To use the Escape's™ auto-fill feature, connect any standard garden hose from a spout to the auto-fill fitting on the front of the unit (see section 2.2). Turn on the hose and the Escape's™ tank will begin to fill up. Once full, the float in the tank will cut off the flow of water into the tank.

To use the pump-out, connect the included pump-out hose to the pump-out connection on the front of the machine using the cam-lock fitting (see section 2.2). Turn on the PUMP OUT switch on the switch plate (see section 1.3). Dirty recovered water will be pumped out of the recovery tank through the pump-out hose. **Please follow any local regulations regarding the disposal of dirty water.** ♦

2.4 - Emptying the Solution & Recovery Tanks

The solution and recovery tanks feature tank drain valves (shown below) so that you can easily empty them into a bucket. Simply lift up on the handle to drain the tanks. ♦

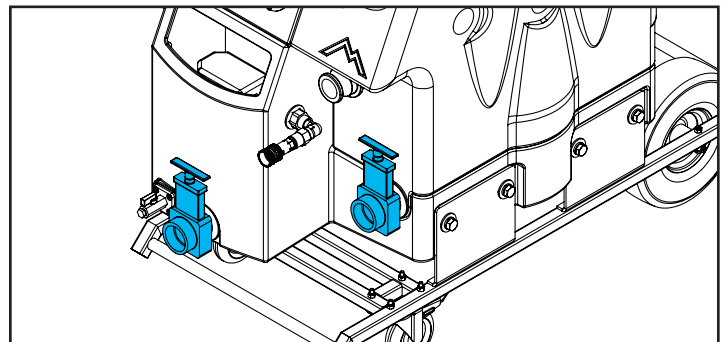

2 - MACHINE OPERATION

2.5 - Preparing the Escape™ for Cold Weather

Freezing temperatures can cause any water in the solution pump to freeze, causing damage to the pump. The ETM-LX-115 Escape™ features a drain valve which can be used to drain remaining water or solution from the pump before storing.

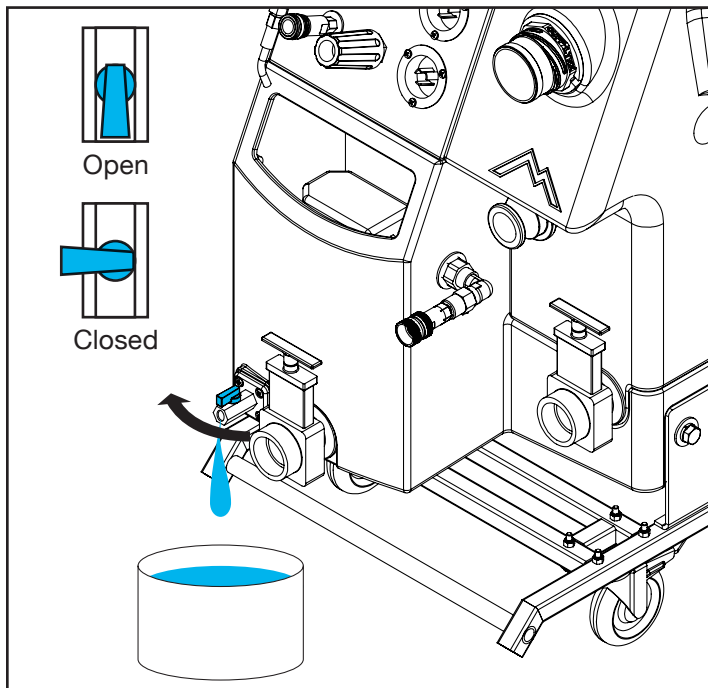

Turn the valve lever to the open position to let out excess water/solution from the pump.

IMPORTANT: Make sure this valve is closed before operating the Escape™. ♦

In order to keep the Escape™ running smoothly and reduce the risk of damage to the machine and subsequent downtime, Mytee recommends following the maintenance schedule below:

Maintenance Item	Daily	Weekly
Clean and inspect tanks.	X	
Clean and inspect hoses.	X	
Check and clean internal filters by twisting off, rinsing with clean water and replacing.	X	
Check power supply cable.	X	
Clean machine with all-purpose cleaner and cloth.	X	
Check spray nozzles.	X	
Flush solution system with Mytee System Maintainer.		X
Remove float shut-off screen from tank and clean.		X
Inspect vacuum hoses for holes and loose cuffs.		X
Inspect spray pattern for clogging. If clogged, remove spray tips and soak them in a recommended liquid neutralizer for up to six hours. To remove spray tip, twist spray tip body counter-clockwise.		X
Lubricate wheels with water resistant oil.		X
Inspect machine for water leaks and loose hardware.		X

3.1 - Filter Maintenance

The Escape™ has a small mesh screen filter on the end of the solution intake hose in the solution tank. This filter should be checked and cleaned after each use. ♦

3.2 - Float Maintenance

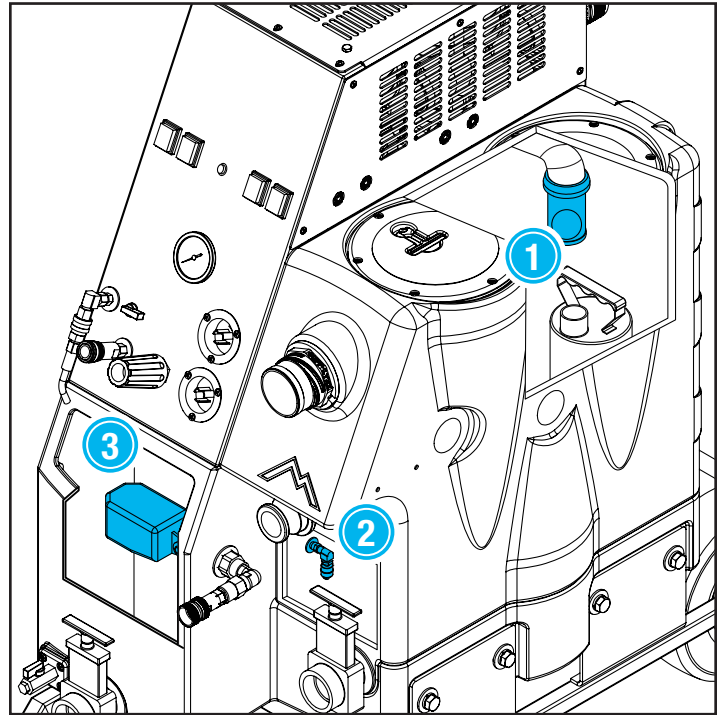

1. Recovery Tank Ball Float

This float prevents recovered dirty water from rising too high and damaging the vacuum motors. Check regularly to make sure the mesh screen is free of debris.

2. Auto Pump-Out Float Switch

This electronic float switch activates the auto pump-out when the water level in the tank reaches it. It is important to remove any debris that might prevent the float switch from activating.

3. Auto-Fill Shut-Off Float

Prevents the auto-fill from over-filling the solution tank. ♦

3.3 - System Maintainer

Weekly flushing of the solution system with Mytee® System Maintainer helps keep lines clean and prevents chemical build-up, improving pump life, performance and pressure.

3 - MACHINE MAINTENANCE

How to use System Maintainer:

1. Mix 1-quart 3601 System Maintainer with 1-quart of warm water.
2. After thoroughly mixing, pour this solution into the solution tank.
3. Turn the pump on **FIRST**, and run solution through your cleaning tool. **NOTE:** The jet should be removed from the cleaning tool in order to prevent clogging due to loosening of deposits in line.
4. Next, with the pump on, begin running the solution through the machine. This allows the solution to break down any build up in the lines.
5. After running all of the solution through the machine, fill the tank with clean, warm water. Run the water through the machine to clear the solution completely out of the tank & lines. ♦

4 - AVAILABLE ACCESSORIES

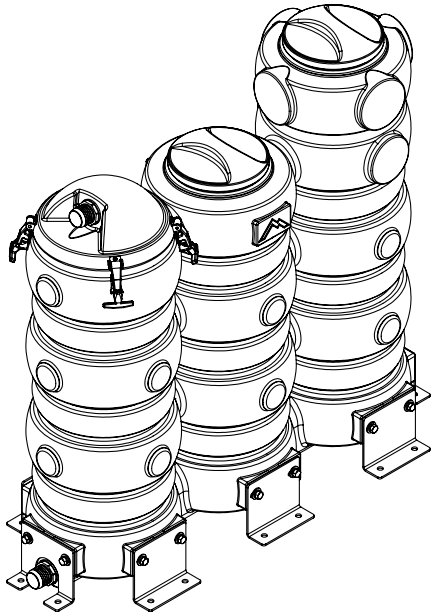

T-80R - Recovery Tank

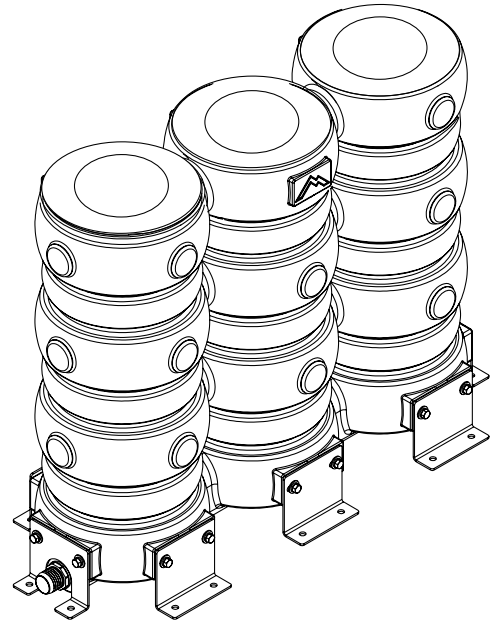

T-80S - Recovery Tank

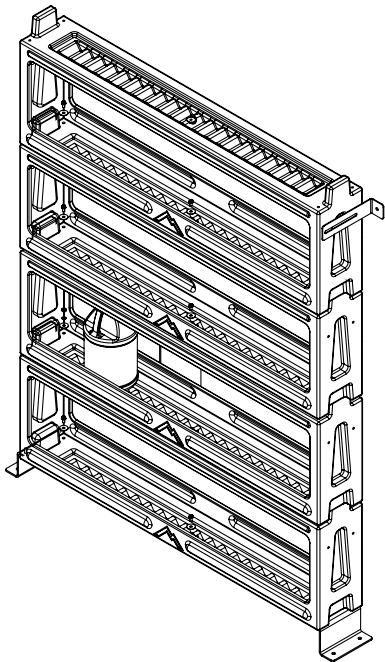

A500 - Stackable Van Shelving System Set

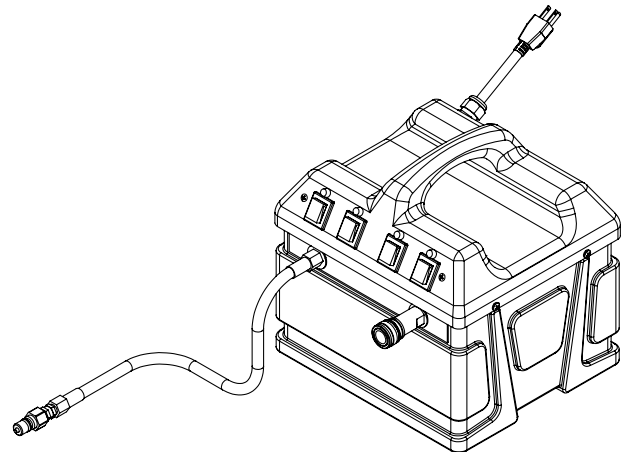

240-120 - Mytee® Hot Turbo In-Line Heater

4 - AVAILABLE ACCESSORIES

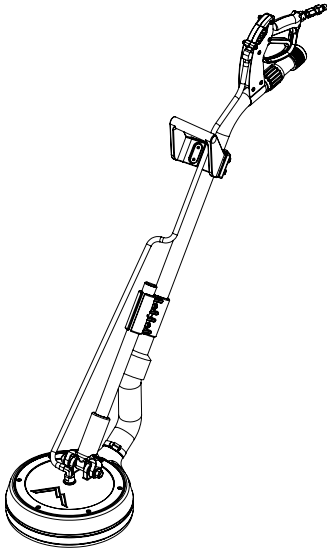

8903 - Wand Style Spinner®

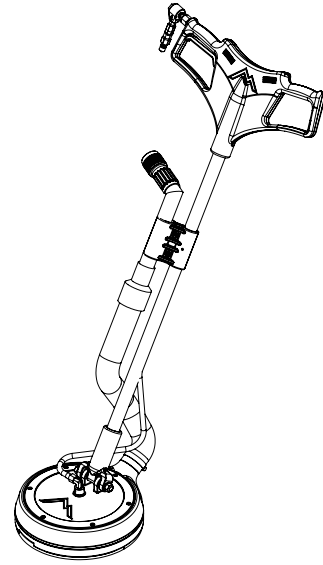

8904 - T-Handle Spinner®

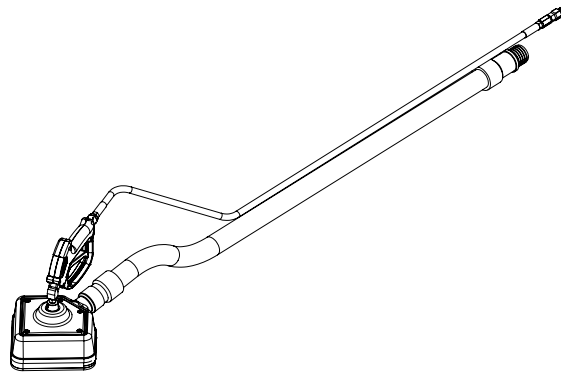

8908 - Counter Spinner®

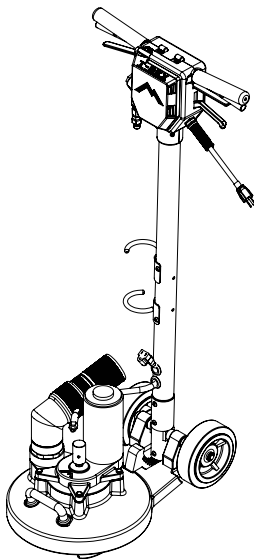

T-REX Jr. 12" Total Rotary Extractor

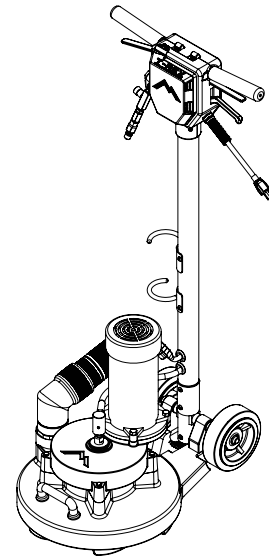

T-REX 15" Total Rotary Extractor

5.1 - Vacuum Troubleshooting

Vacuum is not turning on.	
Possible Cause	Solution
Vacuum may not be getting power.	<p>Check the electrical connections and the switch. Look for loose or damaged wires.</p> <p>To check the switch:</p> <p>Unbolt the switch plate. Take a picture of the layout of the wires or tagging the wires for future reference. Switch the wires from the vacuum switch with the wires from either the pump or heater switch. Turn on the pump or heater switch (whichever one you exchanged wires with). If the vacuum turns on, then you know the vacuum switch is bad.</p>

Vacuum is not producing suction.	
Possible Causes	Solutions
Recovery tank is full.	Empty the recovery tank.
Vacuum hose blockage (if there is no suction or exhaust).	Check for blockage in the hose, starting from the cleaning tool to the machine.
Clogged filter in vacuum tank.	Clean out filter regularly.
Drain valve/cap is loose and is causing air leakage.	Tighten the drain valve/cap.
Hose cuffs are loose and causing air leakage.	Tighten all hose cuffs regularly as may loosen over time. Use a glue to prevent cuffs from coming loose (optional).

Lid on tank is loose and is causing air leakage.	Make sure the lid is tight.
--	-----------------------------

Vacuum blows water out the exhaust.	
Possible Causes	Solutions
Foam building up in the recovery tank.	Use Mytee's Auto Defoamer Kit (Part # A688).

There is a loud grinding noise coming from the vacuum.	
Possible Cause	Solution
Debris has been sucked into the vacuum motor chamber. Usually results from dry vacuuming.	Replace the vacuum motor. To avoid repeat problem, DO NOT dry vacuum with your extractor.

5.2 - Pump Troubleshooting

No water flow.	
Possible Causes	Solutions
Tank is empty.	Fill tank.
Filter is clogged.	Clean the filter.
Pump valves are clogged or damaged.	Rebuild pump.
Pump dump valve on the front of the machine is open.	Close the pump dump valve (Section 2.5).

Low pressure.	
Possible Causes	Solutions
Worn nozzle.	Replace nozzle with a new one of the same size.
Leak in high pressure hose or connections.	Check the hose and connections.
Filter is clogged.	Clean the filter.
Pump valves are clogged or damaged.	Rebuild pump.

5 - TROUBLESHOOTING

Pump pulsates when spraying.	
Possible Causes	Solutions
Filter is clogged.	Clean the filter.
Pump valves are clogged or damaged.	Rebuild pump.

Leaks seen under pump.	
Possible Causes	Solutions
Worn pump seals.	Rebuild pump.
Abrasives in solution have damaged pump seals.	Mix chemical thoroughly and make sure filter is not damaged.

NOTES

NOTES



Mytee Products, Inc.

13655 Stowe Dr.
Poway, CA 92064

www.mytee.com

© 2018 Mytee Products, Inc.
Printed in the USA