



Operator & Parts Manual

# Electric Automatic Floor Scrubber

**Model: 20B-Z**



---

8050907  
REV.01(10-2018)



**READ OPERATOR MANUAL CAREFULLY!**

## HOW TO ORDER PARTS

Please contact your local distributor. Having the following information available will be helpful:

- Machine model name
- Serial number from serial plate
- Part # and quantity (do not order by page number)



### **PROTECT THE ENVIRONMENT**

Please dispose of packaging materials, old machine components such as batteries, hazardous fluids, including antifreeze and oil, in an environmentally safe way according to local waste disposal regulations.



Always remember to recycle.

---

Specifications and parts are subject to change without notice.

**TABLE OF CONTENTS**

SAFETY PRECAUTIONS.....	4
MACHINE COMPONENTS.....	5
PANEL COMPONENTS.....	6
MACHINE SETUP & INSTALLATION.....	7
MACHINE OPERATION.....	8
WHILE OPERATING MACHINE.....	8
TANK DRAINING.....	9
BATTERY CHARGING.....	9
PREVENTATIVE MAINTENANCE.....	9-10
FAULT CODE & SOLUTION.....	11
BASIC TROUBLESHOOTING.....	12
TECHNICAL SPECIFICATIONS.....	13
PARTS LIST.....	14-33
WEAR AND TEAR PARTS.....	34
WIRING DIAGRAM .....	35

## SAFETY PRECAUTIONS

This machine is intended for commercial use. It is designed exclusively to scrub hard floors in an indoor environment and is not constructed for any other use. Only use recommended accessories.

All operators shall read, understand and exercise the following safety precautions:

### 1. Do not operate machine:

- Unless trained and authorized.
- Unless you have read and understand the operators manual.
- In flammable or explosive areas.
- If not in proper operating condition.
- In outdoors areas.

### 2. Before starting machine:

- Make sure all safety devices are in place and operate properly.

### 3. When using machine:

- Go slow on inclines and slippery surfaces.
- Follow all safety guidelines.
- Be very careful when using the machine in reverse.
- Reduce speed when turning.
- Report and fix any damage to machine prior to operating it.
- Never allow children to play on or around.
- Do not operate on inclines that exceed 5% (3°).

### 4. Before leaving or servicing machine:

- Stop on level surface.
- Turn off machine.

### 5. When servicing machine:

- Read operators manual thoroughly prior to operating or servicing this machine.
- Use manufacturer supplied or approved replacement parts.
- Secure machine with wheel blocks prior to jacking the machine up.
- Use approved jack or hoist to safely elevate the machine.
- Disconnect batteries prior to working on machine.
- Wear gloves when handling batteries or battery cables.

- Avoid any contact with battery acid.
- Avoid moving parts. Do not wear loose fitting clothing while servicing machine.



**WARNING: Batteries emit hydrogen gas. Explosion or fire can result from hydrogen gas. Keep sparks and open flames away! Keep battery compartment open when charging.**



**WARNING: Flammable materials can cause an explosion or fire. Do not use flammable materials in tanks.**



**WARNING: Flammable materials or reactive metals can cause explosion or fire. Do not pick up.**

**MACHINE COMPONENTS**

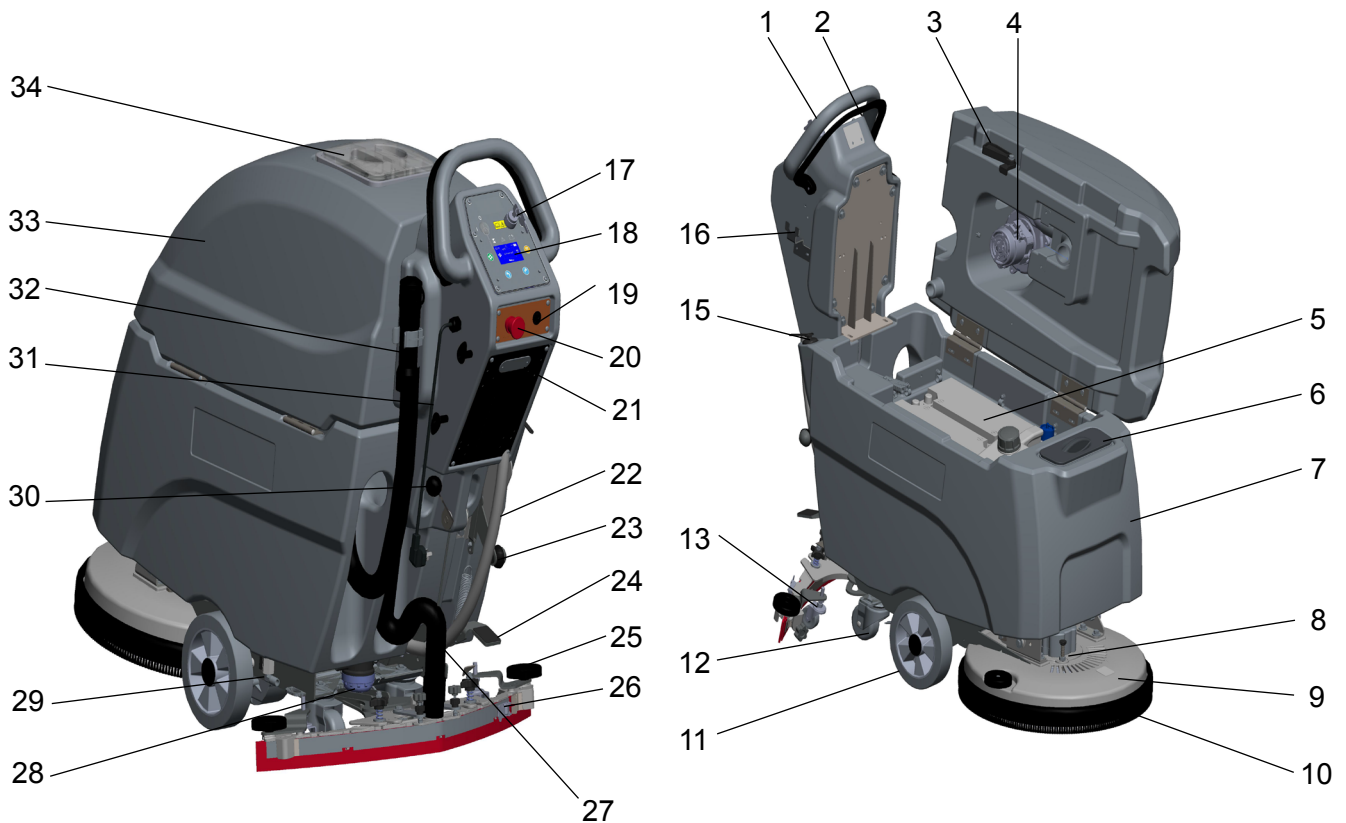

- |   |  |
|---|--|
| 1. Control Handle                             | 19. Emergency Stop Button (Drive Models) |
| 2. Control Handle Start Bail                  | 20. On-board battery charger / Window    |
| 3. Recovery Tank Support Stand                | 21. Solution Tank Level / Drain Hose     |
| 4. Vacuum Motor, 24VDC                        | 22. Heavy Down Pressure Lever            |
| 5. Batteries                                  | 23. Scrub Head Lift Pedal                |
| 6. Bucket Fill Port/ Clean-Out Port           | 24. Bumper Rollers                       |
| 7. Solution Tank                              | 25. Squeegee Assembly                    |
| 8. Motor Hub Lock Pin (Disk Models)           | 26. Squeegee Vacuum Hose                 |
| 9. Scrub Head Assembly                        | 27. Filter Assembly                      |
| 10. Scrub Head Skirt                          | 28. Ball Valve                           |
| 11. Wheels, 8 Inch                            | 29. Squeegee Lift Lever                  |
| 12. Caster, 3.15 Inch                         | 30. Power cord, on-board Battery charger |
| 13. Caster, 2 Inch, Squeegee Blade Adjustment | 31. Recovery Tank Drain Hose             |
| 14. Hose Fill-Port                            | 32. Recovery Tank                        |
| 15. Squeegee Storage Bracket                  | 33. Recovery Tank Cover                  |
| 16. Main Power Key Switch                     |  |
| 17. Control panel (see Panel components)      |  |
| 18. Main controller breaker                   |  |

## PANEL COMPONENTS

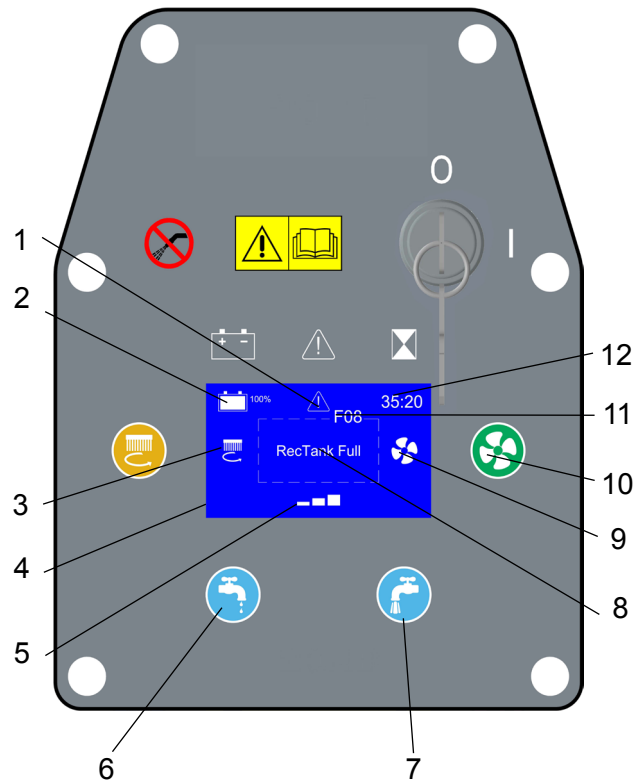

- |                                     |                           |
|-------------------------------------|---------------------------|
| 1. Fault indicator                  | 9. Vacuum motor indicator |
| 2. Battery meter                    | 10. Vacuum motor switch   |
| 3. Brush motor indicator            | 11. Fault code            |
| 4. LED display screen               | 12. Timer                 |
| 5. Solution flow indicator          |                           |
| 6. Solution flow control button (-) |                           |
| 7. Solution flow control button (+) |                           |
| 8. Fault message display area       |                           |

## MACHINE SET UP & INSTALLATION

### UNCRATING MACHINE

Be sure and check packing carton for any damage. Immediately report any damage to carrier. Check the contents of package to ensure that the following items are included:

- Machine
- Requires 2-12V Batteries
- Squeegee assembly
- Battery Charger
- Pad Driver

### INSTALLING BATTERIES

The batteries are already in the machine upon delivery; However you will need to connect the cables to the battery posts.

**⚠ WARNING: Batteries emit hydrogen gas. Explosion or fire can result from hydrogen gas. Keep sparks and open flames away! Keep battery compartment open when charging.**

1. Turn the Main power key switch off.
2. Open recovery tank to gain access to battery compartment.
3. Carefully place the two batteries into the compartment as shown in figure below. Place the battery brace at the rear of the two batteries.

**DO NOT DROP BATTERIES INTO COMPARTMENT!**

4. Connect battery cables to posts in numbered order as shown in drawing below.  
**RED to POSITIVE and BLACK to NEGATIVE.**

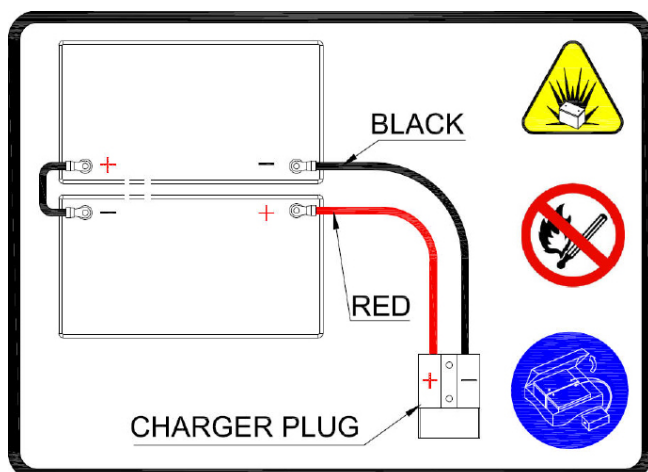

## MACHINE SET UP

### PRE-OPERATION CHECKS

1. Sweep or dust mop the surface to be cleaned.
2. Check battery meter to make sure batteries are fully charged. (See BATTERY CHARGING).
3. Check that squeegee is properly installed.
4. Check that brush / pad is properly installed.

### INSTALLING PAD DRIVER OR BRUSH

1. Ensure that the machine is turned off.
2. Step down on the scrub head lift pedal (see machine components, item #25) to raise the scrub head off the floor.
3. If using a Pad Driver, first attach the appropriate pad to the pad driver surface.
4. Turn the brush motor hub until the slot with the spring clip is visible through the scrub head window.
5. Mount the pad driver or brush to the brush motor hub by lining up the three studs with the three holes in the brush motor hub. Once in the holes, rotate the driver toward the spring clip to lock the pad driver into place.  
If necessary, press down on the motor hub lock pin (see machine components, item # 9) to lock motor hub in place.
6. For Orbital head Model Ultron 20TO, you need to attach a rectangular, 20in(508mm)×14in(356mm) Pad to the Orbital Pad driver. Align the pad to the Orbital pad driver, press from front-to-back and side to side to alignment.

### MOUNTING THE SQUEEGEE ASSEMBLY

1. Lift the squeegee lift lever (see machine components, item #32) to the upward position.
2. Mount the squeegee assembly to the squeegee pivot bracket. Make sure the knobs are completely seated into the slots before securing knobs.
3. Connect the vacuum hose to the squeegee assembly. Loop the hose by using the hose clip provided.
4. Check the squeegee blades for proper adjustment.

# OPERATOR MANUAL

## FILLING THE SOLUTION TANK

The machine is equipped with a hose fill-port (see machine components, item #16) at the rear of the machine, and a bucket fill-port (see machine components, item #6) located under the recovery tank. Before accessing the bucket fill-port make sure that the recovery tank is empty.

Fill the solution tank to the "60L" level on the solution tank sight gauge. When using the bucket fill-port, stop filling when the level reaches the bottom edge of the fill-port.

**NOTE:** When filling the solution tank with a bucket, make sure that the bucket is clean. Do not use the same bucket for filling and draining the machine.

 **WARNING: Do not put any flammable materials into solution tank. This can cause an explosion or a fire. Only use recommended cleaning chemicals. Contact Dealer for recommendations on proper chemicals.**

## MACHINE OPERATION

 **WARNING: Do not operate machine unless you have read and understand this manual.**

1. Lower squeegee assembly to the floor by lowering the squeegee lift lever (see machine components, item #32).
2. Lower the scrub head to the floor by stepping on the scrub head lift pedal (see machine components, item #25).
3. Turn the main power key switch (see machine components, item #18) to the on (I) position.
4. Check the battery meter (see Panel components, item #2), if the battery is very low, there will be a Fault code & message on the LED display screen (see Fault code section), and the Fault indicator will blink continuously accompany an audible alarm. Please DO NOT continue to operate the machine and recharge the batteries immediately.
5. Check the solution flow indicator (see Panel components, item #5), press the solution flow control button (see Panel components, item #6, 7) to a desired flow rate.

**NOTE: Solution will not begin to flow until the control handle bail is pulled.**

6. Turn on the vacuum motor switch (see Panel components, item #10).
7. Ultron 20BA: Pull the control handle bail (see machine components, item #2) backwards to start scrubbing by moving the machine forward.

**NOTE:** 45-60 meters (150-200 ft) per minute is the recommended scrubbing speed.

8. When more brush pressure is needed for heavily soiled areas simply lift the down pressure lever (see machine components, item #24).
9. To stop scrubbing, release the control handle bail, raise the scrub head and the squeegee assembly.

## WHILE OPERATING MACHINE

 **WARNING: Fire or Explosion Hazard. Do Not Pick Up Flammable Materials or Reactive Metals.**

1. Go slow on inclines and slippery surfaces. Do not operate the machine on inclines that exceed 5% (3°).
2. Do not keep the machine in the same position with pad / brush spinning, keep the machine moving to prevent damage to floor finish.
3. If the squeegee assembly leaves streaks on the floor, raise the squeegee off the floor and wipe the blades down with a damp cloth. Pre-sweep the area to prevent leaving streaks on the floor.
4. Pour a recommended defoamer into the recovery tank if excessive foam appears.

 **WARNING: Do not allow foam to enter the float shut-off screen, vacuum motor damage will result. Foam will not activate the float shut-off screen.**

5. Occasionally check the battery meter (see Panel components, item #2). When the battery is very low, stop scrubbing and recharge the batteries.

 **WARNING: When battery is very low, do not continue to operate the machine. Battery damage may result.**

6. When the solution tank runs empty, raise the brush head off the floor. Keep the squeegee down and continue to vacuum until all the dirty water is picked up.

**NOTE:** See **TANK DRAINING** section to learn how to drain recovery and solution tanks.



## CIRCUIT BREAKER

The machine is equipped with a resettable circuit breaker (see machine components, item #21) to protect the Main controller. If the circuit breaker should trip, it can't be reset immediately. You must first determine what caused the breaker to trip, and allow the Controller to cool down and then you can manually reset the circuit breakers.

**NOTE:** Contact Dealer for machine repairs.

## HOUR METER

The hour meter (see Panel components, item #12) records the number of total hours the brush motor has been powered on. Use the hour meter to determine when to perform recommended maintenance procedures and to record service history.

## **TANK DRAINING**

1. Turn the machine off on.
2. With the squeegee and scrub head in their "up" position, transport machine to approved area for draining tank(s).

## DRAINING THE RECOVERY TANK

Any time scrubbing is completed, or when refilling solution tank, the recovery tank should be drained and cleaned.

**⚠ WARNING: If the recovery tank is not drained when the solution tank has been refilled, foam or water may enter the float shut-off screen and cause damage to the vacuum motor.**

1. While holding the drain hose (see machine components, item #25) upward, remove the cap and lower hose to drain.
2. Open the recovery tank cover and rinse out the tank. Use a rag to remove any excess dirt.
3. Clean the float shut-off screen and debris tray located in the recovery tank .

## DRAINING THE SOLUTION TANK

Any time scrubbing operation is completed, the solution tank should be drained and cleaned.

1. Pull the solution tank level hose (see machine components, item #23) off the hose fitting, this will allow the solution to flow freely into a bucket or floor drain.
2. Remove the cover of the filter assembly (see machine components, item #29) to drain the

solution tank, check the filter screen and clean up it if necessary.

3. Rinse the solution tank with clean water after every use. This will help prevent chemical buildup and clogging of the solution lines.
4. After rinsing out the tank, securely reconnect the tank level hose to the hose fitting, replace the filter assembly cover and be sure the filter screen and the "O" ring is in the correct position.

## **BATTERY CHARGING**

**⚠ WARNING: Fire or Explosion Hazard. Batteries Emit Hydrogen Gas. Keep Sparks and Open Flame Away. Keep Battery Compartment Propped Open When Charging.**

**NOTE:** Use only approved chargers with the following specifications:

- **Automatic shut-off circuit**
  - **Deep cycle charging**
  - **Output current of 10-20 Amps**
  - **Output voltage of 24 volts**
1. Place machine in a well ventilated area.
  2. Turn the machine off.
  3. If charging wet (lead acid) batteries check the fluid level before charging.
  4. Connect the charger's AC power supply cord (see machine components, item #33) to a properly grounded receptacle.
  5. Prop up the recovery tank by the support stand (see machine components, item #3) for ventilation when charging.
  6. The charger will automatically begin to charge and will automatically shut-off once the batteries are fully charged.
  7. Upon completion of charging, disconnect the AC power supply cord.

## **PREVENTATIVE MAINTENANCE**

**⚠ WARNING: Before performing any maintenance on the machine, be sure that the power is turned off, or the batteries are disconnected!**

**⚠ WARNING: Repairs are to be completed by Dealer only. Any repairs completed by unauthorized persons will void the warranty.**

# OPERATOR MANUAL

---

## DAILY MAINTENANCE

1. Remove pad driver/ brush and clean with approved cleaner.
2. Drain recovery and solution tanks completely and rinse out with clean water. Visually check the recovery tank for debris and clean out as necessary.
3. Raise the squeegee assembly off floor and wipe it down with a damp towel. Be sure to store the squeegee in the up position.
4. Remove the float shut-off assembly and rinse it out with clean water.
5. Clean machine with an approved cleaner and a damp towel.
6. Recharge the batteries.
7. Check the condition of the squeegee blade wiping edge, rotate blade if worn.

## MONTHLY MAINTENANCE

1. Clean the battery tops to prevent corrosion.
2. Check for loose battery cable connections.
3. Inspect and clean the recovery tank cover seal. Replace it if damaged.
4. Lubricate all grease points and pivot points with silicon spray and approved grease.
5. Check the machine for loose nuts and bolts.
6. Check the machine for leaks.

## MOTOR MAINTENANCE

1. Contact Dealer for any motor maintenance.
2. Motor should have the brushes checked every 250 hours. Brushes should be replaced when they are worn to a length of 10 mm or less.

## BATTERY MAINTENANCE



**WARNING: Batteries emit hydrogen gas and an explosion or fire can result. Keep sparks and fire away from batteries at all times.**



**WARNING: Whenever servicing batteries, be sure to wear protective gloves. Avoid contact with battery acid at all times.**

**NOTE:** For the best machine performance, keep batteries charged at all times. Do not let them sit in a discharged condition.

1. Always follow the battery charging directions as outlined in the BATTERY CHARGING section of this manual.
2. Keep battery tops and terminals free from corrosion. A strong solution of baking soda

and water is the best way to keep the batteries corrosion free. DO NOT ALLOW THE BAKING SODA / WATER SOLUTION TO ENTER THE BATTERY CELLS.

3. Use a wire brush with the baking soda solution to properly clean the battery posts and connections.
4. Check battery connections for wear and loose terminals. Replace if necessary.

## MACHINE STORAGE

1. Always store the machine indoors.
2. Always store the machine in a dry area.
3. Always store the machine in its upright position.
4. Always store the machine with the pad driver/ brush raised off the floor.
5. Always store the machine with the squeegee assembly raised off the floor.
6. If storing in an area which may reach freezing temperatures, be sure to drain all fluids from the machine prior to storage. Any damage caused by freezing temperatures will not be covered by the warranty.
7. Drain the recovery tank.
8. Drain the solution tank of all fluid.

**FAULT CODE & SOLUTION**

The machine is equipped with a LED display screen (see Panel components, item # 4), the LED screen will display the operating hours (see Panel components, item # 12) and the battery level status (see Panel components, item # 2).

When the machine detects a fault, there will be a Fault code (see Panel components, item #11) & Fault message (see Panel components, item #8) display on the LED screen, and the Fault indicator (see Panel components, item #1) will flash continuously, accompany an audible alarm occasionally.

Once fault occurring, please DO NOT continue operate the machine unless the fault are eliminated. Turn off the machine, then to solve the fault, the fault code & message will be eliminated when machine restarts.

If the fault is occurred frequently, or the fault can't be eliminated, please contact Dealer.

Please refer to the below table to determine the fault cause and the solution.

FAULT CODE	FAULT MESSAGE	MODEL	FAULT CAUSE	SOLUTION
		20B-Z		
F01	Lower Brush Deck	●	Brush deck is off the floor	Release the control handle bail or Lower the Brush deck
F04	Vac Mtr O.L. RE-START!	●	Vacuum motor overload	Turn off the machine, after a moment, RE-START machine
F06	Bru Mtr O.L. RE-START!	●	Brush motor overload	
F08	RecTank Full	●	Recovery tank is full or Bad Solution level sensor	Drain the Recovery tank/Replace the solution level sensor
F10	Batt Low Charge Batt	●	Battery is low	Charge the battery
F11	Batt Empty Charge Batt NOW	●	Battery is empty	Charge the battery NOW
F16	Control Unit Overheat! Wait	●	Control Unit Overheat	Turn off the machine, after a moment, RE-START machine
F17	Replace Control Unit	●	Control Unit Fault	Replace the control unit
F21	Check Vac Mtr	●	Bad Vacuum motor or wiring	Check the vacuum motor / Wiring
F22	Check Soln Solenoid	●	Solution solenoid wiring fault	Check the wiring & Contactors
F23	Replace Soln solenoid	●	Bad Solution solenoid	Replace the solution solenoid
F25	Check Brush Motor	●	Bad brush motor	Check the brush motor / Wiring
F41	Release Handle	●	Operation mistake	Release the control handle bail
F42	Replace Control Unit	●	Bad Control Unit	Contact service center, Replace the Control Unit
F44	Replace Control Unit	●	Bad Control Unit	
F45	Return Control Unit	●		
F46	Return Control Unit	●		
F47	Return Control Unit	●		
F48	Return Control Unit	●		

## BASIC TROUBLESHOOTING

PROBLEM	CAUSE	SOLUTION
Machine will not operate	Control handle bail not pulled	Pull control handle bail
	Batteries need to be charged	Charge batteries
	Bad batteries	Replace batteries
	Loose batteries connection	Tighten the connector
	Main control unit circuit breaker tripped	Reset main control unit breaker
	Faulty key switch	Contact Dealer
Brush motor will not operate	Scrub head is raised off floor	Lower scrub head
	Faulty scrub head (up/down) switch	Contact Dealer
	Faulty control handle bail switch	Contact Dealer
	Faulty brush motor or wiring	Contact Dealer
	Worn motor carbon brushes	Contact Dealer
Machine does not propel (Drive model)	Faulty transaxle motor or wiring	Contact Dealer
	Worn motor carbon brushes	Contact Dealer
Vacuum motor will not operate	Faulty vacuum motor or wiring	Contact Dealer
	Worn motor carbon brushes	Contact Dealer
Little or no solution flow	Ball valve set too low or shut off	Turn on the ball valve
	Solution flow control knob set too low or shut-off	Adjust solution control flow knob
	Clogged solution tank filter or solution hose	Clean solution tank filter or flush out solution hose
	Clogged solution solenoid valve	Remove valve and clean
Poor water pick up	Recovery tank is full	Drain recovery tank
	Loose drain hose cap	Tighten cap
	Clogged float shut-off screen located in recovery tank	Clean screen
	Clogged squeegee assembly	Clean squeegee assembly
	Worn squeegee blades	Replace or rotate squeegee blades
	Incorrect squeegee blade deflection	Adjust squeegee blade height
	Loose vacuum hose connections	Secure hose connections
	Clogged vacuum hose	Remove clogged debris
	Damaged vacuum hose	Replace vacuum hose
	Recovery tank cover not in place	Properly position cover
	Damaged recovery tank cover seal	Replace seal
	Faulty vacuum motor	Contact Dealer
	Low battery charge	Recharge batteries
Short run time	Low battery charge	Fully recharge batteries
	Defective batteries	Replace batteries
	Faulty battery charger	Repair or replace battery charger
	Down pressure lever is set for extra scrub head pressure	Lower down pressure lever

**TECHNICAL SPECIFICATIONS**

<b>MODEL</b>	<b>20B-Z Brush Assist</b>
<b>DIMENSIONS L</b>	55.7 in / 1,415 mm
<b>DIMENSIONS W</b>	22 in / 560 mm
<b>DIMENSIONS H</b>	44.9 in / 1,140 mm
<b>WEIGHT</b>	210 lbs / 95 Kg
<b>WEIGHT WITH BATTERIES</b>	410 lbs / 185 Kg
<b>RECOVERY TANK CAPACITY</b>	17.2 Gal / 65 L
<b>SOLUTION TANK CAPACITY</b>	15.9 Gal / 60 L
<b>SQUEEGEE WIDTH</b>	30 in / 762 mm
<b>CLEANING PATH WIDTH</b>	20 in / 500 mm (Disk)
<b>PRODUCTIVITY RATE</b>	19,375 ft <sup>2</sup> / 1,800 m <sup>2</sup> h
<b>DRIVE SYSTEM</b>	Brush Assisted
<b>TRAVEL SPEED, MAXIMUM</b>	N/A
<b>MINIMUM AISLE TURN</b>	63 in / 1,600 mm
<b>PAD/BRUSH PRESSURE</b>	65 lbs / 30 Kg Min 100 lbs / 45 Kg Max
<b>SOLUTION FLOW RATE</b>	0 ~ 0.37 Gal / Min 0 ~ 1,400 ml / Min
<b>BRUSH MOTOR</b>	0.75hp / 0.55KW 220 RPM
<b>VIBRATIONS @ CONTROLS</b>	N/A
<b>VACUUM MOTOR</b>	0.7hp / 0.5KW
<b>WATER LIFT - AIR FLOW</b>	45 in / 1,143 mm
<b>BATTERIES</b>	2-12, 130AH @ 20 hr
<b>RUN TIME PER CHARGE</b>	3.5 Hours
<b>VOLTAGE DC</b>	24V
<b>DECIBEL RATE AT OPERATOR'S EAR, INDOORS</b>	68dB(A)
<b>GRADE LEVEL, MAX</b>	5% (3°)

RECOVERY TANK GROUP

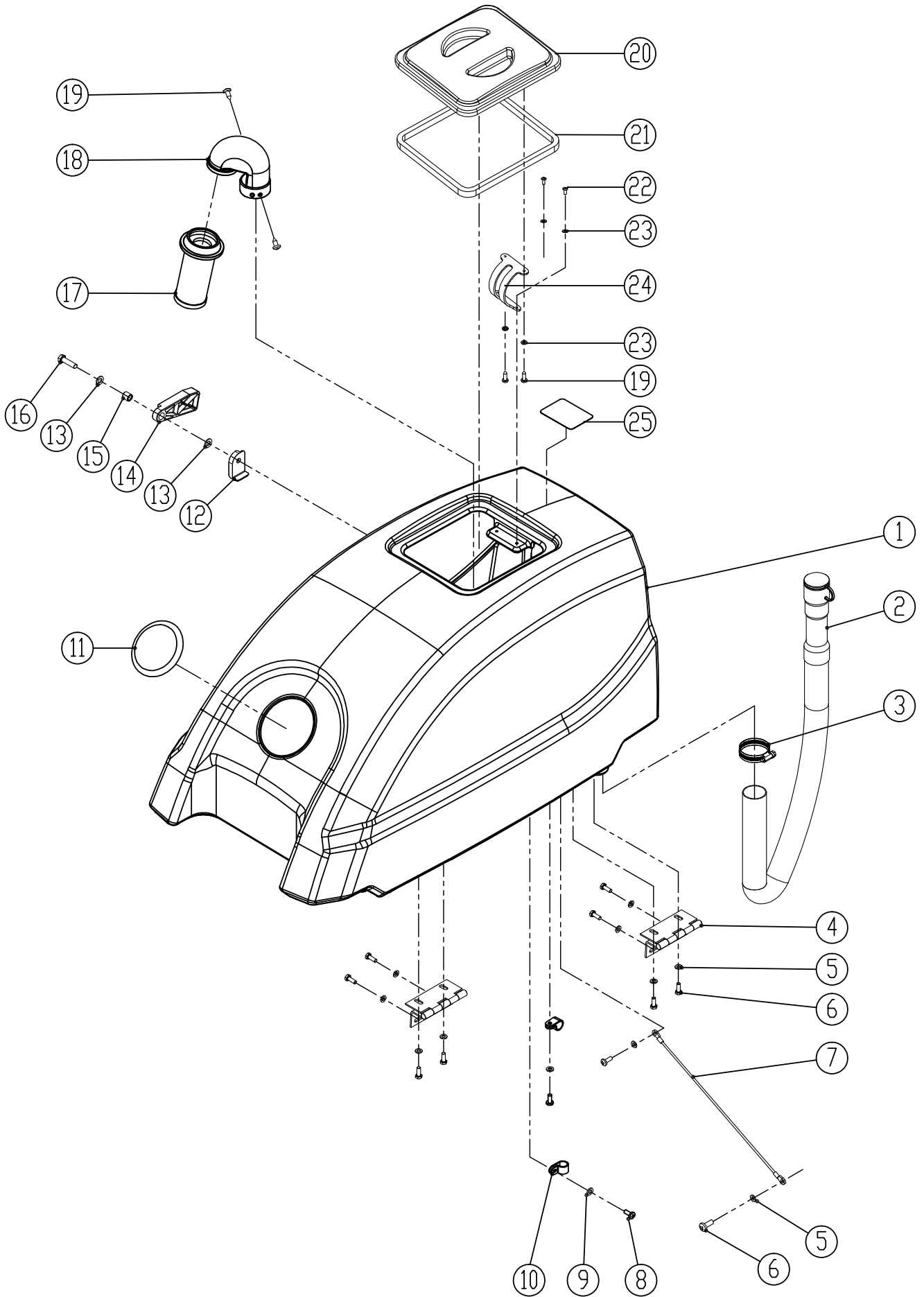

**RECOVERY TANK GROUP**

<b>DIA NO.</b>	<b>PART NUMBER</b>	<b>DESCRIPTION</b>	<b>NO. REQ'D</b>
1	8136003	RECOVERY TANK COVER	1
2	8131010	DRAIN HOSE	1
3	1962050	CLAMP	1
4	8111300	HINGE ASSEMBLY	2
5	1421618	FLAT WASHER M6×DIA18×1.6	10
6	1021616	HEX BOLT M6×16	10
7	8131020	CABLE	1
8	1221512	SCREW M5×12	2
9	1421510	FLAT WASHER M5×DIA10×1	2
10	8113009	NYLON, CLAMP	2
11	8050112	LOGO	1
12	8111008	BRACKET	1
13	1421816	FLAT WASHER M8×DIA16×1.6	2
14	8111007	RECOVERY TANK SUPPORT	1
15	8115404	SLEEVE, P/M	1
16	1021830	HEX BOLT M8×30	1
17	8111015	FLOAT, SHUT-OFF	1
18	2320220	BEND	1
19	1321210	SCREW, SELF-TAPPING, ST4×10	4
20	2320216	COVER, CLEAR	1
21	2320218	GASKET, CLEAR WINDOW	1
22	1221410	SCREW M4×10	2
23	1421409	FLAT WASHER M4.3×DIA9×0.8	4
24	2320217	RUBBER HINGE	1
25	8111022	WARNING LABEL	1

VACUUM FAN GROUP

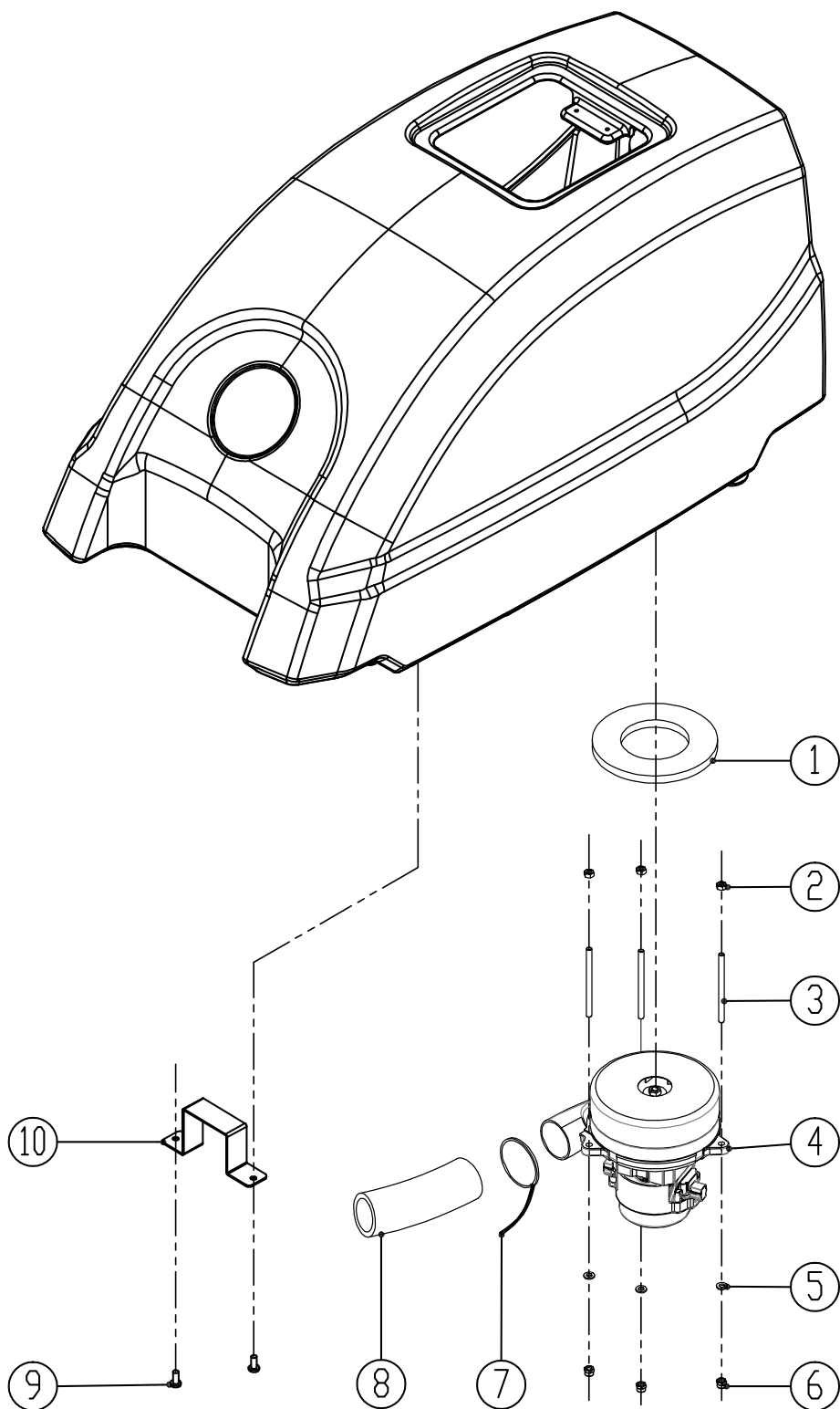



**VACUUM FAN GROUP**

<b>DIA NO.</b>	<b>PART NUMBER</b>	<b>DESCRIPTION</b>	<b>NO. REQ'D</b>
1	8112005	GASKET, VACUUM MOTOR	1
2	1121605	HEX NUT M6	3
3	8112006	STUD M6×92	3
4	8132050	VACUUM MOTOR , 24VDC, 2-STAGE, KIT	1
5	1421612	FLAT WASHER M6×DIA12×1.6	3
6	1123608	LOCK NUT M6	3
7	1914300	TIE, NYLON, 5×300	1
8	8132007	MUFFLER, VACUUM MOTOR	1
9	1221512	SCREW M5×12	2
10	8133012	BRACKET	1

**SOLUTION TANK GROUP**

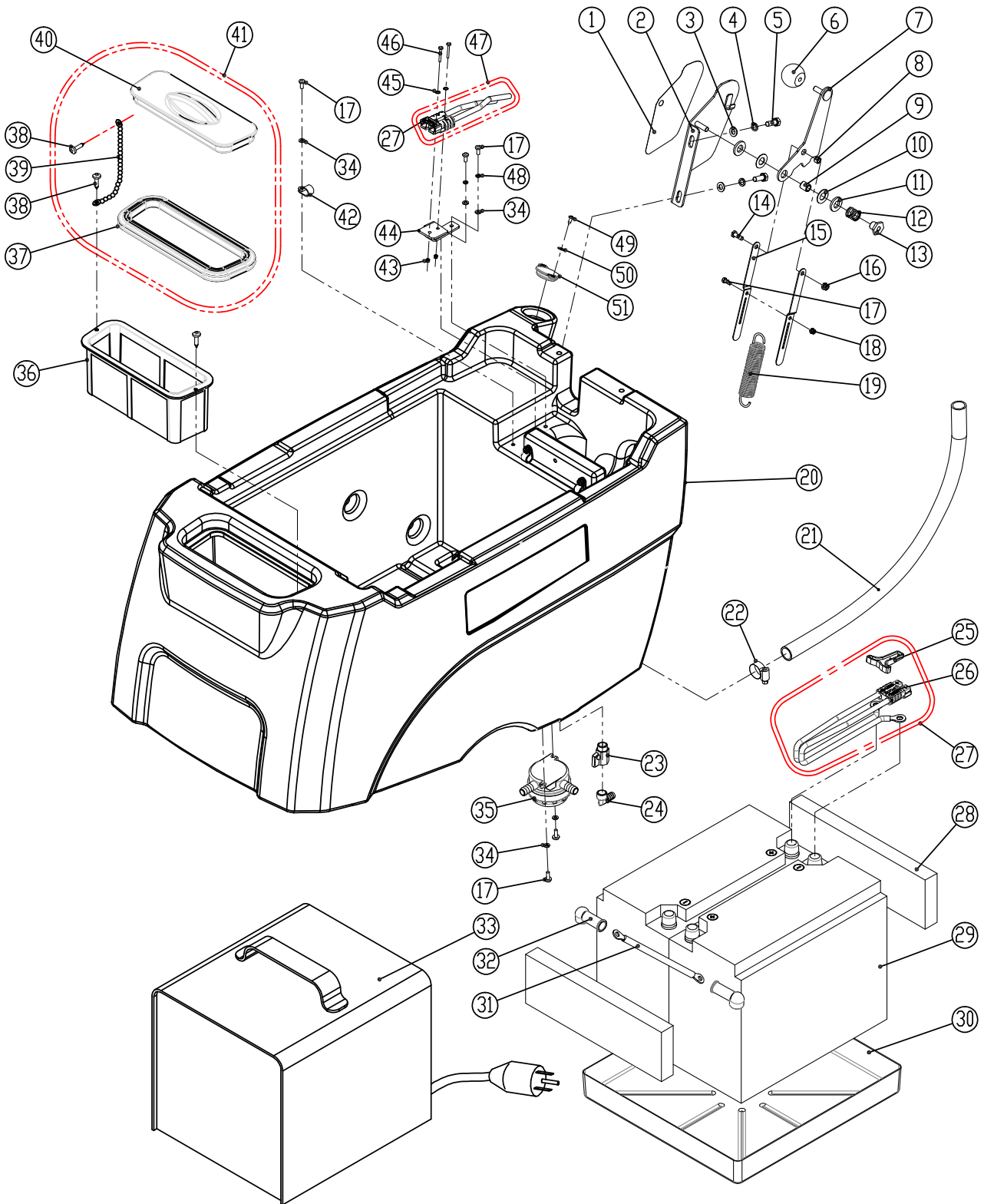

**SOLUTION TANK GROUP**

<b>DIA NO.</b>	<b>PART NUMBER</b>	<b>DESCRIPTION</b>	<b>NO. REQ'D</b>
1	8113115	DOWN PRESSURE LABEL	1
2	8113101	DOWN PRESSURE LEVER BRACKET	1
3	1421816	FLAT WASHER M8×DIA16×1.6	2
4	1422821	LOCK WASHER M8	2
5	1021820	HEX BOLT M8×20	2
6	8113104	BALL KNOB	1
7	8113106	DOWN PRESSURE LEVER	1
8	8113112	BUSHING	1
9	8113110	SLEEVE, P/M	1
10	8113111	NYLON FLAT WASHER DIA12.9×DIA25.4×0.8	2
11	8113109	THRUST BEARING	2
12	8113114	SPRING	1
13	8113107	RETAINER, SPRING	1
14	8113103	BOLT M6×18	1
15	8113108	LINK, SPRING	2
	8133108	LINK, SPRING, ORBITAL HEAD MODEL	2
16	1123608	LOCK NUT M6	1
17	1221512	SCREW M5×12	12
18	1123507	LOCK NUT M5	1
19	8133113	SPRING	1
20	8136002	SOLUTION TANK	1
21	8133007	CLEAN TUBING	1
22	1962025	CLAMP 16-25mm	1
23	8119005	BALL VALVE, G1/2	1
24	8119007	ELBOW G1/2	1
25	8113021	HANDLE, CONNECTOR	1
26	8113020	CONNECTOR	2
27	8114731	BATTERY CONNECT CABLE, ASSEMBLY	1
28	8113013	SPACER, BATTERY	2
29	8113011	BATTERY, 12TB115, 115AH, HOPPECKE	2
30	8133010	BATTERY, 6-EVF-100, 110AH, CHILWEE	2

## PARTS LIST

### SOLUTION TANK GROUP

DIA NO.	PART NUMBER	DESCRIPTION	NO. REQ'D
31	8133020	BATTERY, EV12A-A, 120AH, DISCOVER	2
	8113012	BATTERY TRAY	1
	8114750	BATTERY CONNECT CABLE, BLACK	1
32	8114751	JACKET, BATTERY TERMINAL, BLACK	4
33	8114721	OFF BOARD BATTERY CHARGER (OPTION)	1
34	1421510	FLAT WASHER M5×DIA10×1	11
35	8119100	FILTER ASSEMBLY	1
36	6210107	FILTER	1
37	8050152	SEAL	1
38	1321210	SCREW, SELF-TAPPING, ST4×10	3
39	8050153	CHAIN	1
40	8050156	LID, SOLUTION TANK FILL PORT	1
41	8050150-BK	LID, KIT	1
42	8113009	NYLON, CLAMP	7
43	1123305	LOCK NUT M3	2
44	8113010	BRACKET, CONNECTOR MOUNTING	1
45	1434300	LOCK WASHER, TOOTH, M3	2
46	1211325	SCREW M3×25	2
47	8134783	BATTERY CONNECT CABLE, ASSEMBLY	1
48	1422513	LOCK WASHER M5	2
49	1321110	SELF-TAPPING SCREW ST3.5×10	1
50	1421409	FLAT WASHER M4×DIA9×0.8	1
51	8133002	CAP, SOLUTION FILL	1

**CONTROL CONSOLE GROUP ( 20B-Z )**

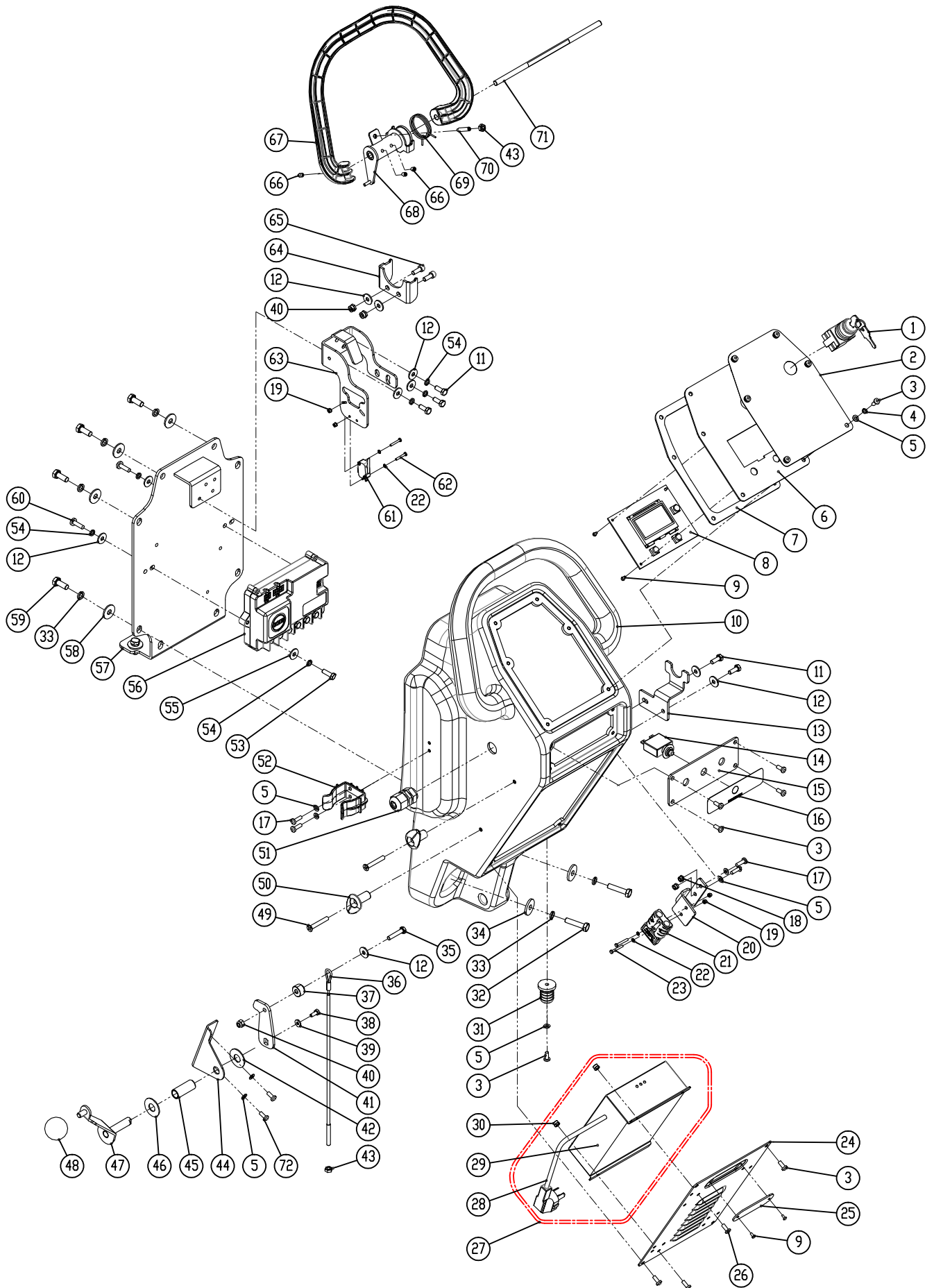

## PARTS LIST

### CONTROL CONSOLE GROUP ( 20B-Z )

DIA NO.	PART NUMBER	DESCRIPTION	NO. REQ'D
1	8114709	KEY SWITCH	1
	8114752	KEY	1
2	8134727	CONTROL PANEL DECAL, Ultron 20BA	1
3	1221512	SCREW M5×12	17
4	1422513	LOCK WASHER M5	6
5	1421510	FLAT WASHER M5×DIA10×1.0	13
6	8134720	CONTROL PANEL, Ultron 20BA	1
7	8134015	GASKET	1
8	8134736-G	CONTROL PANEL PCB, Ultron 20BA (WET FLOODED/ EN)	1
9	1221306	SCREW M3×6	7
10	8134005A	CONTROL HOUSING, Ultron 20BA	1
11	1021616	HEX BOLT M6×16	5
12	1421618	PLAIN WASHER M6×DIA18×1.6, SS	10
13	8114008	BRACKET, SQUEEGEE STORAGE	1
14	8310740	CIRCUIT BREAKER, 5A	1
15	8134006	PLATE, CIRCUIT BREAKERS MOUNTING	1
16	8144025	LABEL, CIRCUIT BREAKER	1
17	1221515	PH SCREW M5×15	4
18	1123507	LOCK NUT M5	2
19	1123305	LOCK NUT M3	4
20	8113010	BRACKET, CONNECTOR MOUNTING	1
21	8113020	CONNECTOR	1
22	1434300	LOCK WASHER, TOOTH, M3	4
23	1211325	SCREW M3×25	2
24	8134060	PLATE, ON BOARD BATTERY CHARGER	1
25	8134061	CLEAR COVER	1
26	1221412	SCREW M4×12	4
27	8132010-US	ON BOARD BATTERY CHARGER, KIT (OPTION)	1
28	8112030A	BATTERY CHARGER POWER CORD, KIT	1
29	8132010A	ON BOARD BATTERY CHARGER	1
30	1123406	LOCK NUT M4	4
31	8114005	CONNECTOR	1
32	1021840	HEX BOLT M8×40	2
33	1422821	LOCK WASHER M8	12
34	1421828	FLAT WASHER M8×DIA28×3	2
35	1021630	HEX HEAD BOLT M6×30, SS	1

**CONTROL CONSOLE GROUP ( 20B-Z )**

<b>DIA NO.</b>	<b>PART NUMBER</b>	<b>DESCRIPTION</b>	<b>NO. REQ'D</b>
36	8134082	CABLE, SQUEEGEE LIFT	1
37	8014101	LIFTING ROPE SPACER	1
38	1021610	HEX HEAD BOLT M6×10, SS	1
39	1421616	FLAT WASHER M6×DIA16×1.0	1
40	1123608	LOCK NUT M6	3
41	8014012	BAFFLE	1
42	8113111	NYLON FLAT WASHER DIA12.9×DIA25.4×0.8	1
43	1121605	HEX NUT M6	2
44	8134501	BRACKET	1
45	8134081	SLEEVEE	1
46	1421132	FLAT WASHER M12×DIA32×1.5	1
47	8134080	SQUEEGEE LIFTING HANDLE	1
48	8113104	BALL KNOB M8	1
49	1222641	SUNK HEAD SCREW M6×40	2
50	8210112	HOOK, POWER CORD	2
51	8014054	STRAIN RELIEF	1
52	6210111	CLAMP, DRAIN HOSE	1
53	1023612	HEX BOLT M6×12, COPPER	6
54	1422616	LOCK WASHER, M6	11
55	1423612	FLAT WASHER M6×DIA12×1, COPPER	6
56	8134790	MAIN CONTROLLER, ULTRON 20BA	1
57	8134070	REAR PLATE, CONTROL CONSOLE	1
58	1421824	FLAT WASHER M8×DIA24×2	10
59	1021820	HEX BOLT M8×20	10
60	1221620	PH SCREW M6×20	2
61	8114712	MICRO SWITCH	1
62	1021320	SCREW M3×20	2
63	8134022	BRACKET, SWITCH	1
64	8114402	BRACKET, SPRING	1
65	1521616	SCREW M6×16, HEX SCOKET	2
66	1534608	SET SCREW M6×8	4
67	8134301	LEVER, BAIL	1
68	8114300	ACTUATOR	1
69	8114306	SPRING	1
70	1535630	SET SCREW M6×30	1
71	8114101	SHAFT	1
72	1021512	HEX HEAD BOLT M5×12, SS	2

**FRAME & WHEEL GROUP ( 20B-Z )**

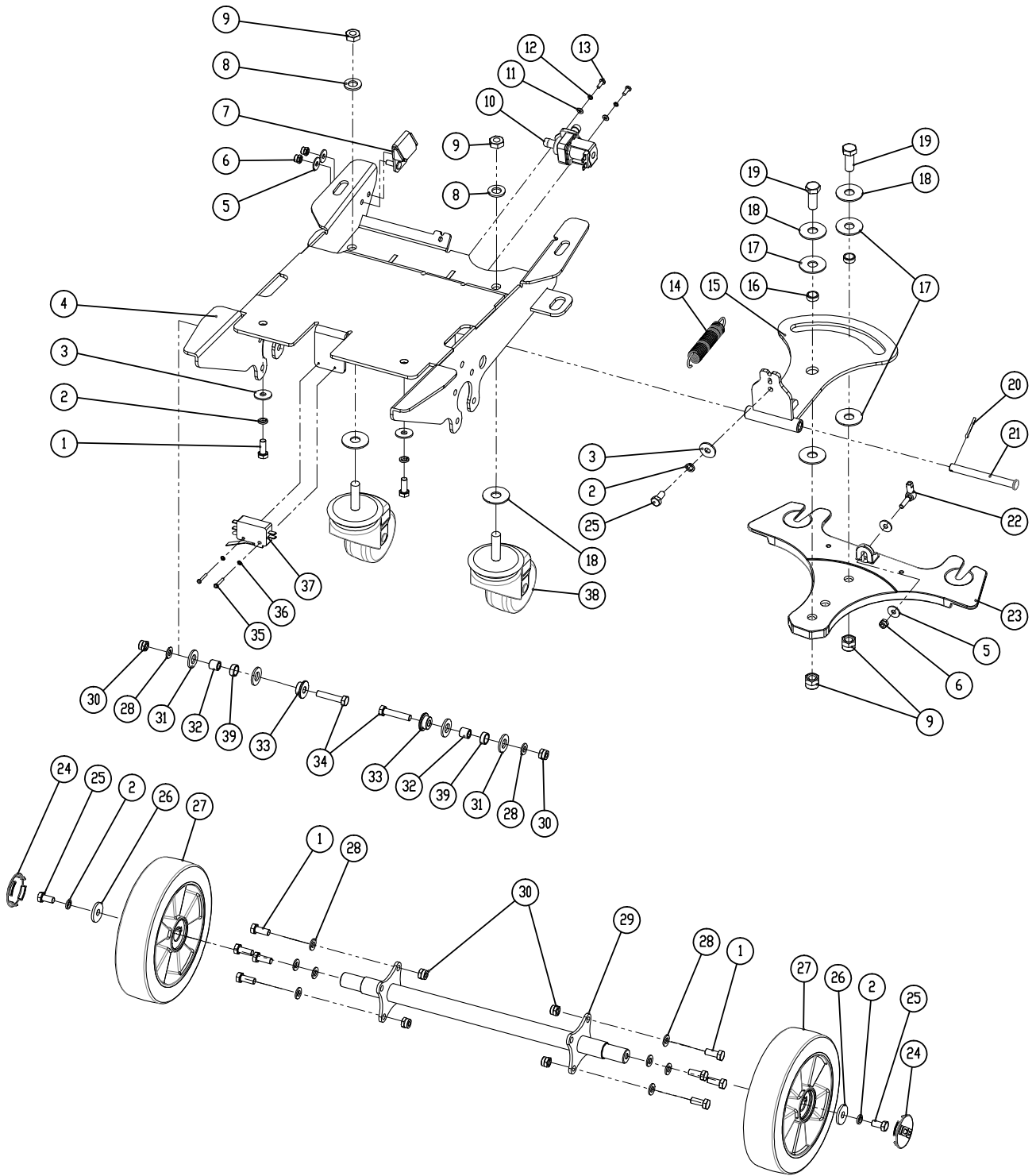



**FRAME & WHEEL GROUP ( 20B-Z )**

<b>DIA NO.</b>	<b>PART NUMBER</b>	<b>DESCRIPTION</b>	<b>NO. REQ'D</b>
1	1021820	HEX BOLT M8×20	12
2	1422821	LOCK WASHER M8	7
3	1421824	FLAT WASHER M8×DIA24×2	5
4	8145100	MAIN FRAME	1
5	1421618	FLAT WASHER M6×DIA18×1.6	4
6	1123608	LOCK NUT M6	3
7	8115300	BRACKET, PEDAL LOCKING	1
8	1421124	FLAT WASHER M12×DIA24×2.5	4
9	1123115	LOCK NUT M12	4
10	8119003	SOLENOID VALVE, 24VDC	1
11	1421409	FLAT WASHER M4×DIA9×0.8	2
12	1422411	LOCK WASHER M4	2
13	1221412	SCREW M4×12	4
14	8115004	SPIRNG	1
15	8135010	BRACKET, SQUEEGEE LIFT	1
16	8115005	AXLE SLEEVE	2
17	8135001	PLASTIC THRUST WASHER M12×DIA30×1.5	4
18	1421132	FLAT WASHER M12×DIA32×1.5	4
19	1021230	HEX BOLT M12×30	2
20	1645324	COTTER 3.2×24	1
21	8115003	PIN	1
22	8114511	BALL JOINT M6	1
23	8115001	BRACKET, SQUEEGEE MOUNTING	1
24	8115206	COVER, WHEEL	2
25	1021816	HEX BOLT M8×16	3
26	1421828	FLAT WASHER M8×DIA28×3	2
27	8115200	WHEEL, 8 INCH	2
	1612607	BALL BEARING, 6004LU	4
28	1421816	FLAT WASHER M8×DIA16×1.6	10
29	8135405	SHAFT	1
30	1123810	LOCK NUT M8	10
31	8117007	NYLON WASHER DIA12.9×DIA24×2.5	4
32	8115404	BEARING, JOURNAL	2
33	8145001	BUSHING	2
34	1021840	HEX BOLT M8×40	2
35	1211325	SCREW M3×25	2
36	1434300	LOCK WASHER, TOOTH, M3	2
37	8014071	MICRO SWITCH 20A	1
38	8115500	CASTER, SWIVEL, 80MM	2
39	8115405	SLEEVE, P/M	2

**SCRUB HEAD GROUP (20B-Z)**

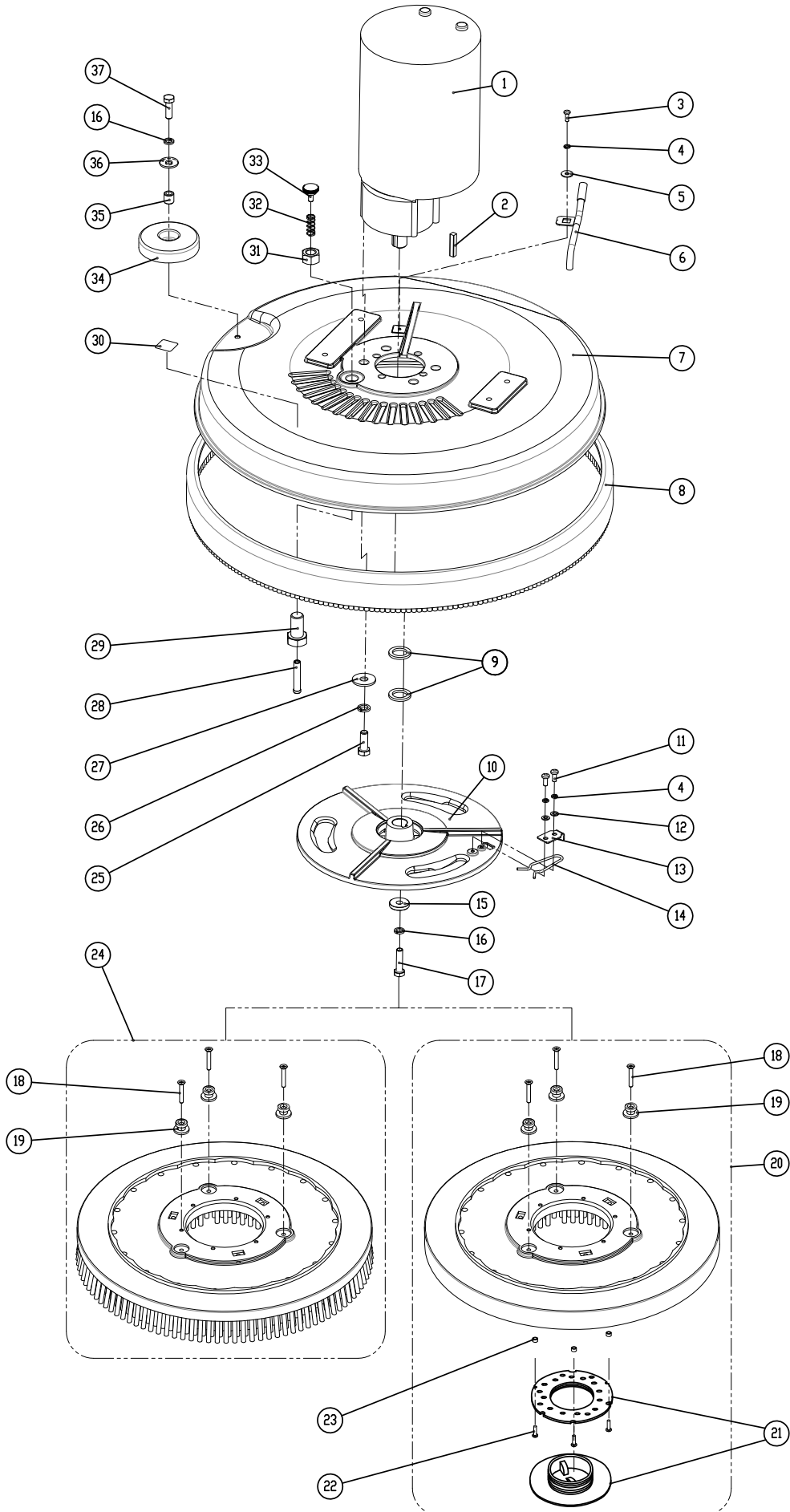

**SCRUB HEAD GROUP (20B-Z)**

<b>DIA NO.</b>	<b>PART NUMBER</b>	<b>DESCRIPTION</b>	<b>NO. REQ'D</b>
1	8116200	BRUSH MOTOR, 24VDC 1.0HP, KIT	1
	8116007	BRUSH MOTOR CARBON BRUSH	2
2	1656433	KEY	1
3	1221412	SCREW M4×12	1
4	1422513	LOCK WASHER M5	3
5	1421518	FLAT WASHER M5×DIA18×2	1
6	8116100	WATER SUPPLY TUBE	1
7	8116006	SCRUB HEAD HOUSING	1
8	8116020	BUMPER, SCRUB HEAD	1
9	8116001	SPACER	2
10	8116008	HUB, DRIVE, 3 LUG	1
11	1221512	SCREW M5×12	2
12	1421510	FLAT WASHER M5×DIA10×1	2
13	8116002	BRUSH CLAMP PLATE	1
14	8116003	SPRING CLIP	1
15	8116010	FLAT WASHER DIA8.5×DIA25.4×4.5	1
16	1422821	LOCK WASHER M8	2
17	1023815	HEX BOLT 5/16-18×1.5" UNC	1
18	1222635	SCREW, M6x35	6
19	8116030	STUD	6
20	9040019	19" PAD DRIVER	1
	9040019K	19" PAD DRIVER (OPTION)	1
21	9000001	BIG MOUTH	1
	9000003	CENTER-LOK 3 (OPTION)	1
22	1321325	SELF-TAPPING SCREW, ST4.8×25	3
23	8116040	SPACER	3
24	9050020	20" BRUSH, 0.7mm PP BRISTLE (OPTION)	1
	9050020E	20" BRUSH, 0.5mm PP BRISTLE (OPTION)	1
25	1023010	HEX BOLT 3/8-16×1" UNC	4
26	1422026	LOCK WASHER M10	4
27	1421030	FLAT WASHER M10×DIA30×2.5	4
28	8116202	PIN	1
29	8116205	SCREW M14×20	1
30	8111023	WARNING LABEL	1
31	1121913	HEX NUT M14	1
32	8116204	SRPING	1
33	8116210	KNOB M6	1
34	8116078	PROTECTIVE WHEEL	1
35	8115404	SLEEVE, P/M	1
36	1421824	FLAT WASHER M8×DIA24×2.0	1
37	1021825	HEX BOLT M8×25	1

**SCRUB HEAD LIFT GROUP (20B-Z)**

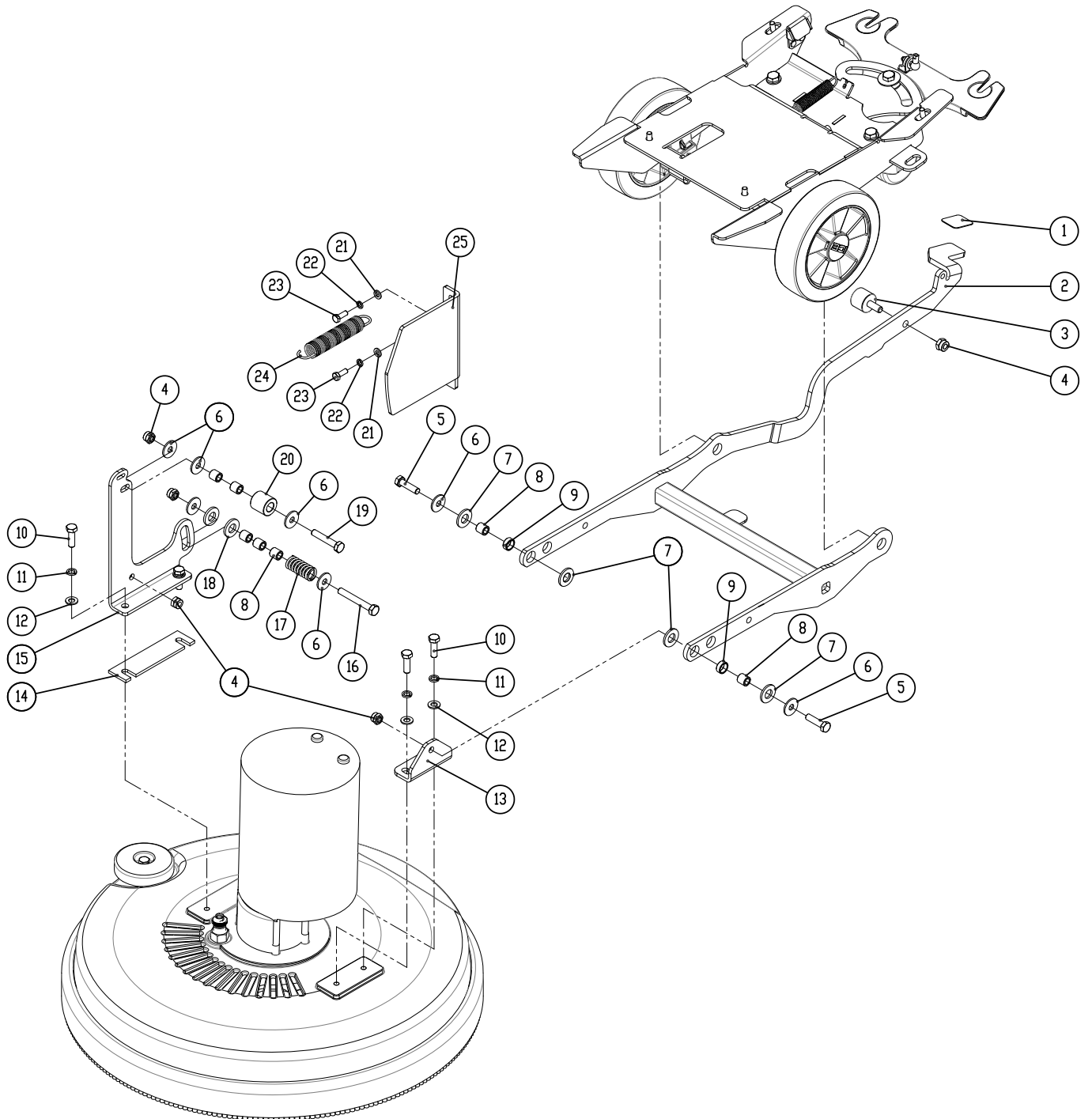

**SCRUB HEAD LIFT GROUP (20B-Z)**

<b>DIA NO.</b>	<b>PART NUMBER</b>	<b>DESCRIPTION</b>	<b>NO. REQ'D</b>
1	8137006	NON-SLIP MAT	1
2	8137100	BRACKET, SCRUB HEAD LIFT	1
3	8133151	BUMPER	1
4	1123810	LOCK NUT M8	5
5	1021830	HEX BOLT M8×30	2
6	1421824	FLAT WASHER M8×DIA24×2	6
7	8117007	NYLON WASHER DIA12.9×DIA24×2.5	4
8	8115404	BEARING, JOURNAL	7
9	8115405	SLEEVE, P/M	2
10	1021825	HEX BOLT M8×25	4
11	1422821	LOCK WASHER M8	4
12	1421816	FLAT WASHER M8×DIA16×1.6	4
13	8117002	LEFT BRACKET	1
14	8117005	SPACER (ULTRON 20BA)	1
15	8117003	RIGHT BRACKET	1
16	1022860	HEX BOLT M8×60	1
17	8117008	SPRING	1
18	8113109	BEARING, THRUST	2
19	1022845	HEX BOLT M8×45	1
20	8117004	ROLLER	1
21	1421612	FLAT WASHER M6×DIA12×1.6	2
22	1422616	LOCK WASHER M6	2
23	1021616	HEX BOLT M6×16	2
24	8117009	SPRING	1
25	8117001	BRACKET, GUIDE	1

SQUEEGEE GROUP

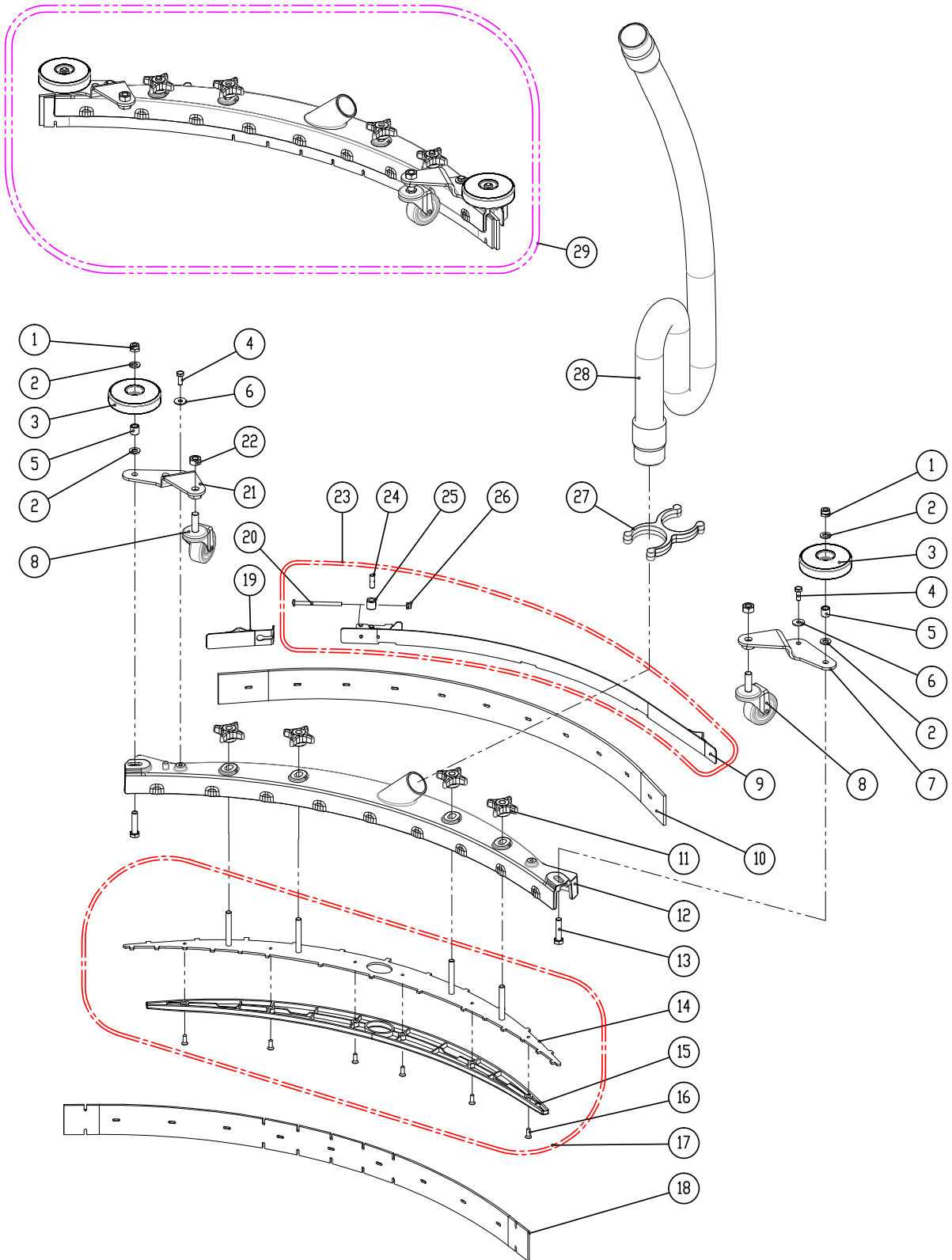

**SQUEEGEE GROUP**

<b>DIA NO.</b>	<b>PART NUMBER</b>	<b>DESCRIPTION</b>	<b>NO. REQ'D</b>
1	1123810	LOCK NUT M8	2
2	1421824	FLAT WASHER M8×DIA24×2.0	4
3	8116078	PROTECTIVE WHEEL	2
4	1021616	HEX BOLT M6×16	2
5	8115404	BEARING, JOURNAL	2
6	1421612	FLAT WASHER M6×DIA12×1.6	2
7	8118300	RIGHT BRACKET	1
8	8118400	CASTER, 2 INCH	2
9	8118600	CLAMP ASSEMBLY, SQUEEGEE	1
10	8118022	SQUEEGEE BLADE, REAR, LINATEX	1
11	8118003	STAR KNOB M8	4
12	8118004	SQUEEGEE HOUSING	1
13	1021835	HEX BOLT M8×35	2
14	8118009	STAINLESS STEEL RETAINER, SQUEEGEE	1
15	8118008	PLASTIC SPACER	1
16	1222515	COUNTERSUNK FLAT HEAD SCREW M5×15	6
17	8118010	RETAINER KIT	1
18	8118021	SQUEEGEE BLADE, FRONT, LINATEX	1
19	8118610	SHORT CLAMP ASSEMBLY	1
20	1221575	SCREW M5×75	1
21	8118200	LEFT BRACKET	1
22	1121008	HEX NUT M10	2
23	8118600A	CLAMP ASSEMBLY	1
24	8118624	SHAFT	1
25	8118623	SPACER	1
26	1123507	LOCK NUT M5	1
27	8118109	HOLDER VACUUM HOSE	1
28	8118006	VACUUM HOSE	1
29	8118000-BK	SQUEEGEE ASSEMBLY, LINATEX	1

SOLUTION GROUP

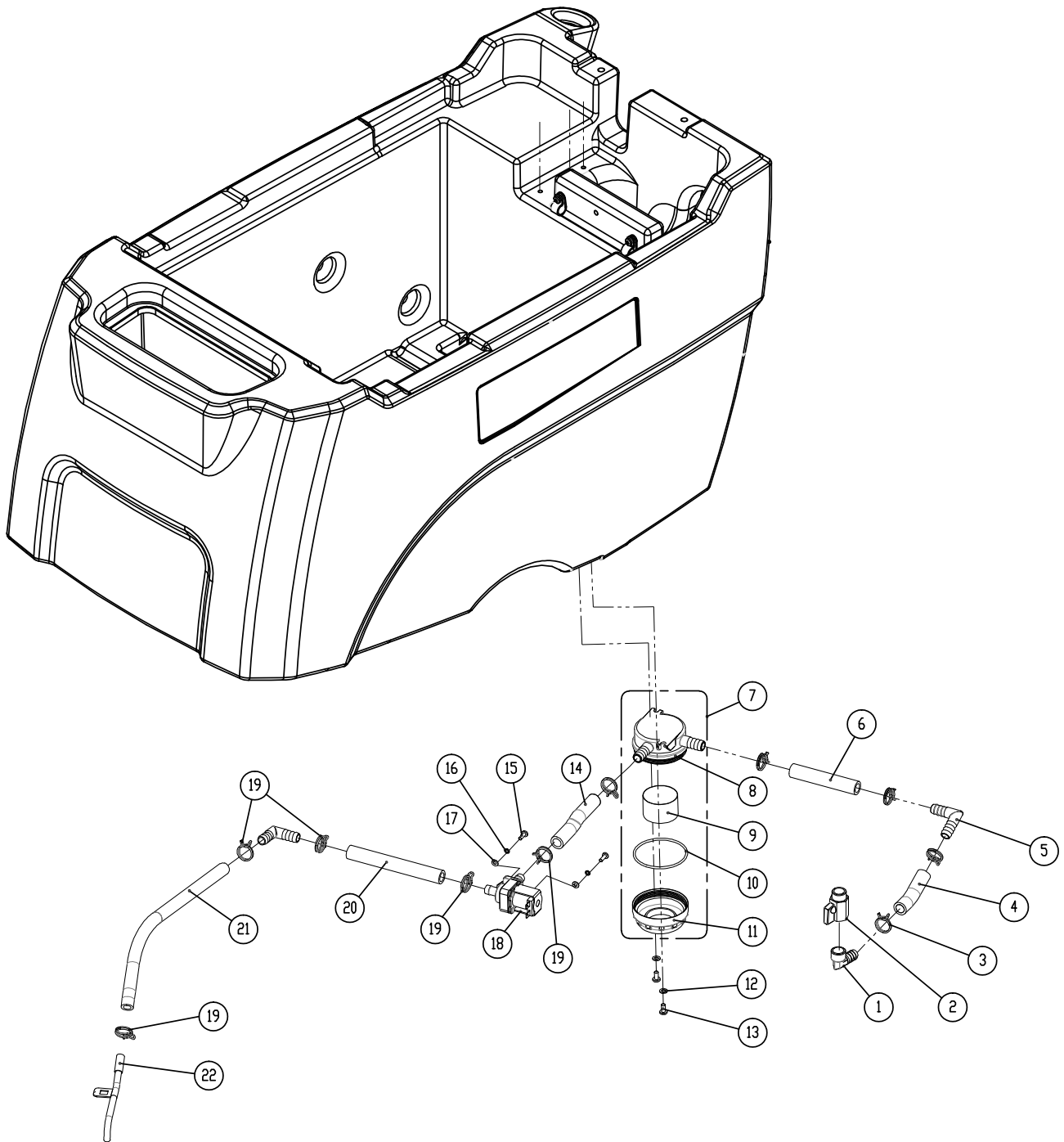



**SOLUTION GROUP**

<b>DIA NO.</b>	<b>PART NUMBER</b>	<b>DESCRIPTION</b>	<b>NO. REQ'D</b>
1	8119007	ELBOW G1/2	1
2	8119005	BALL VALVE, G1/2	1
3	8119006	CLAMP	5
4	8119201	TUBING ID=12MM L=70MM	1
5	8119002	ELBOW, TUBING BARB	2
6	8119202	TUBING ID=12MM L=100MM	1
7	8119200	FILTER ASSEMBLY, 40 MESH	1
8	8119101	BASE, FILTER ASSEMBLY	1
9	8119104	SCREEN, FILTER, 40 MESH	1
10	1622760	O RING	1
11	8119102	CAP, FILTER ASSEMBLY	1
12	1421510	FLAT WASHER M5×DIA10×1	2
13	1221512	SCREW M5×12	2
14	8119202	TUBING ID=12MM L=100MM	1
15	1221412	SCREW M4×12	2
16	1422411	LOCK WASHER M4	2
17	1421409	FLAT WASHER M4×DIA9×0.8	2
18	8119003	SOLENOID VALVE, 24VDC	1
19	1962016	CLAMP, 10-16mm	5
20	8119203	TUBING ID=12MM L=135MM	1
21	8119204	TUBING ID=10MM L=360MM	1
22	8116100	WATER SUPPLY TUBE	1

## **WEAR AND TEAR PARTS**

---

### **WEAR AND TEAR PARTS**

<b>DIA NO.</b>	<b>PART NUMBER</b>	<b>DESCRIPTION</b>	<b>NO. REQ'D</b>
1	8115200	WHEEL, 8 INCH	2
	1612607	BEARING, BALL, 6004, 8" WHEEL	4
2	8116078	PROTECTIVE WHEEL	3
3	8118021	SQUEEGEE BLADE, FRONT, LINATEX	1
4	8118022	SQUEEGEE BLADE, REAR, LINATEX	1
5	9050020	20" BRUSH, 0.7MM PP BRISTLE, BLACK. (OPTIONAL)	1
	9050020E	20" BRUSH, 0.5MM PP BRISTLE, BLUE. (OPTIONAL)	1
6	9040019	19" PAD HOLDER	1
	9040019K	19" PAD HOLDER.(OPTIONAL)	1

# WIRING DIAGRAM

## WIRING DIAGRAM (20B-Z)

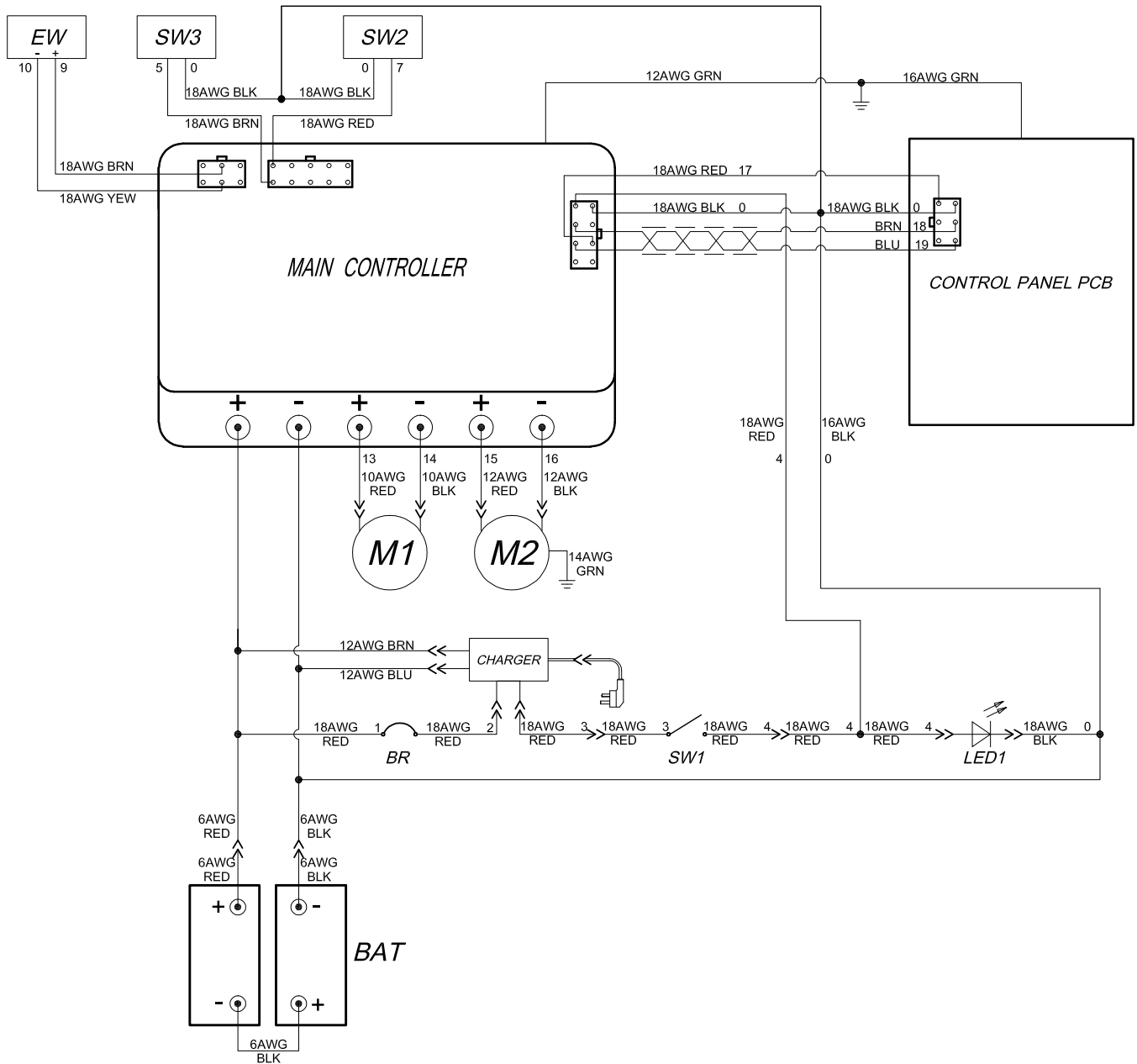

BAT: 2-12V Batteries

BR: Main controller circuit breaker, 5A

SW1: Main power key switch

LED1: Running lights

CHARGER: On board battery charger

M1: Brush motor

M2: Vacuum motor

MAIN CONTROLLER: Main controller

CONTROL PANEL PCB: Control panel PCB

EW: Solution solenoid valve switch

SW3: Control handle start bail switch

SW2: Safe switch, Scrub head lifting