



OWNER'S MANUAL

**HARD SURFACE
ATTACHMENT TOOL**

MADE IN USA

CAUTION

General Precautions

The Stingray attachment tool must be attached to an external operating system (extractor or truckmount) in order to properly work and operate to the standard instructions mentioned in this manual.

Warning!

TMI's Stingray attachment tool is designed for use on hard surfaces, as per instructions written in this manual. Any deviation from its proper use or purpose and the consequential damage that may occur is the sole responsibility of the end user.

Do not attempt to repair the Stingray attachment. See your authorized service dealer.

Do not expose this attachment to extreme temperatures.

Do not use unauthorized replacement parts.

The Stingray attachment was tested before shipping and antifreeze may remain in the plumbing system. The user must flush out any remaining antifreeze before the first use. Make sure to use antifreeze if storing the attachment in extremely cold weather.

Storage after use:

Make sure to set the attachment tool in standing position or storage position after each use or store for a long period of time. This will prevent from damaging squeegees, brush and other parts of the attachment tool.

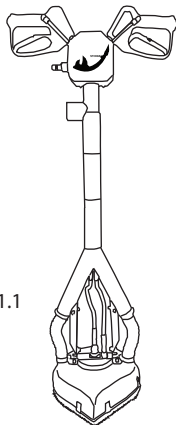

Image 1.1

Standing position = Storage position

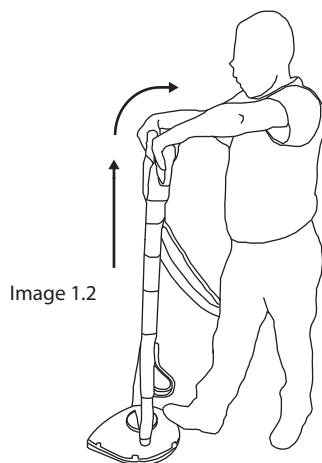

Image 1.2

Softly step on on the base, lift handle with both hands, and pull towards your body to unlock the top handle assembly. Bring handle assembly back to the standing position to lock the handle to the base for storage.

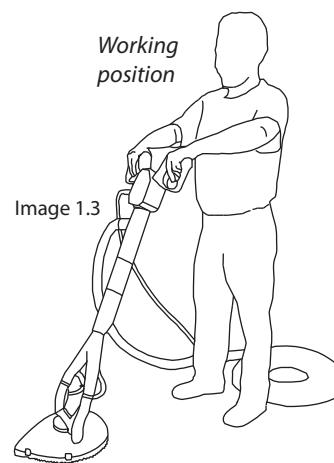

Image 1.3



Pull up handles to unlock pin from the bottom bracket

TABLE OF CONTENTS

CAUTION	1
TABLE OF CONTENTS	2
LIMITED WARRANTY	3
WARRANTY REGISTRATION	4
Owner's warranty information	
ASSEMBLE OF UNIT	6
SAFETY INSTRUCTIONS	7
ATTACHMENT TOOL OVERVIEW	8
ATTACHMENT SET UP	9
OPERATING THE ATTACHMENT	10
Before operating	
Operating	
After operating	
With portable extractor and/or truckmount	
PREVENTATIVE MAINTENANCE	12
OPERATING THE ATTACHMENT	13
How to use attachment tools	
TROUBLESHOOTING:	15
Attachment and electrical system (extractor)	

LIMITED WARRANTY

All equipment and accessories are thoroughly inspected and tested before leaving the factory. They are warranted to be free of defects from workmanship and materials for one year from date of original purchase. (proof of purchase is required).

Labor: 90 days from initial purchase

Parts: 1 year, excluding normal wear and tear items

Polyethylene body: 5 years limited warranty

Should any trouble develop during this period, please contact your dealer or manufacturer to receive a Return Guarantee Authorization number (RGA #). Return the parts or extractor that need to be replaced. If after an inspection it is determined to be under warranty, the factory will repair or replace (manufacturer's discretion) the parts or equipment and return parts or equipment at no charge. Note: Credit, repair or replacement will not be given to any parts or equipment without the above mentioned RGA#.

Proof of purchase is necessary to establish the date of the original sale. Receipt of purchase or warranty registration can be used as proof of purchase. It is extremely important to register your purchase by sending Timbucktoo MFG., Inc. the warranty registration form within 10 days of purchase (Page 4).

This warranty is in lieu of all other warranties expressed or implied, and no person is authorized to give any other warranty, assume obligation or liability on the manufacturer's behalf.

This Warranty does not apply when:

- Repairs that are required because of normal wear and tear
- Repairs have been made or attempted by others
- Items have been abused, misused or improperly maintained
- Modifications or alterations have been made to the equipment

LIMITATION OF REMEDY:

In no event shall seller be liable for any incidental, consequential or special damages of any kind or nature whatsoever. Including but not limited to lost profits arising from or in anyway connected with this agreement or items sold hereunder, whether alleged to arise from breach of contract, express or implied warranty, or in tort, including without limitation, negligence, failure to warn or strict liability.

ENTIRE AGREEMENT / GOVERNING LAW:

This agreement and warranty shall be governed in all respects by the law of the State of California. No actions arising out of the items sold hereunder or this Agreement may be brought by either party more than two (2) years after the cause of action occurs. All mediation or litigation will take place in the County of Los Angeles in California.

WARRANTY REGISTRATION

PLEASE SIGN AND MAIL WITHIN 10 DAYS FROM THE SALE DATE FOR VALID WARRANTY

PLEASE PRINT OR TYPE (SEND TO DEALER)

PURCHASED FROM (DEALER NAME):

ADDRESS:

CITY, STATE, ZIP:

TELEPHONE:

DATE OF PURCHASE:

SERIAL NUMBER:

MODEL NUMBER:

PLEASE PRINT OR TYPE (SEND TO TIMBUCKTOO MFG., INC.)

DEALER NAME:

ADDRESS:

CITY, STATE, ZIP:

DATE SOLD:

PURCHASER'S NAME:

ADDRESS:

TELEPHONE:

DATE OF PURCHASE:

SERIAL NUMBER:

MODEL NUMBER:

Signature:

Print Name:

OWNER'S WARRANTY INFORMATION

DATE OF PURCHASE:	KEEP FOR YOUR OWN RECORDS
SERIAL NUMBER:	
MODEL NUMBER:	
PURCHASED FROM (DEALER NAME):	
ADDRESS:	
CITY, STATE, ZIP:	
TELEPHONE:	

BLANK PAGE

ASSEMBLE OF UNIT

The Stingray attachment tool is delivered in two parts, a simple assembly is required to use the attachment tool right away. (Image 6.1)

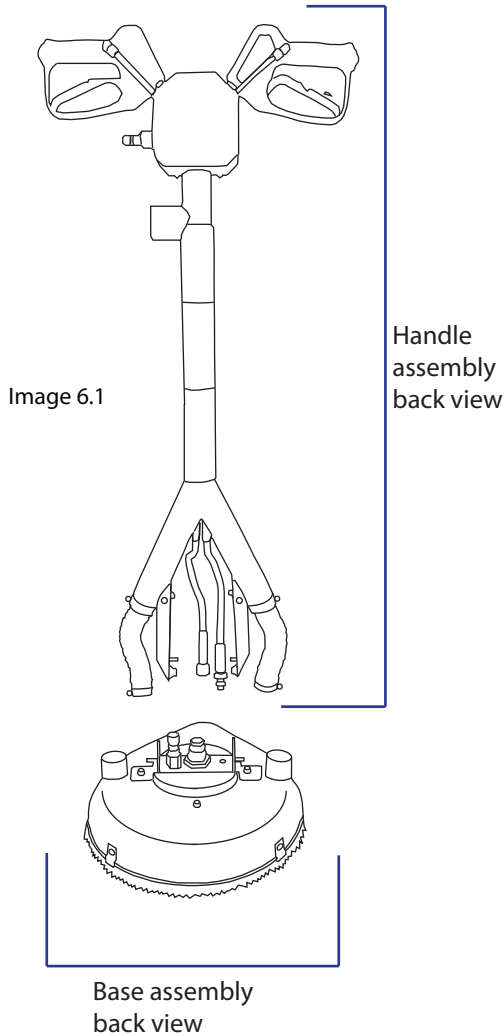

1. Attach the U-brackets in the handle to the U-brackets in the base with the included bolts, washers and nuts (Image 6.2)

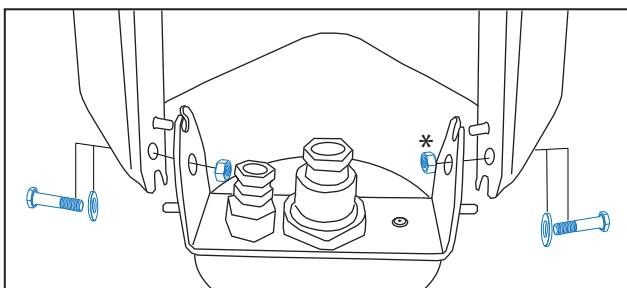

Image 6.2

To assemble the attachment you will need a regular flat head screwdriver and two standard 7/16" open-end wrenches

2. Connect the vacuum hoses to the vacuum hose connections in the base of the housing using the screwdriver to tighten the hose clamps
3. Connect the two solution hoses (male and female) to the fitting connections in the base bracket (Image 6.3)

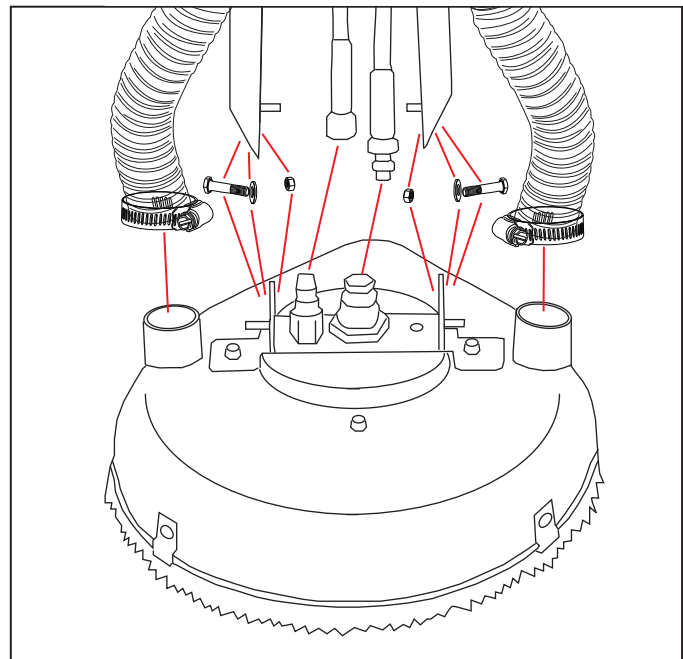

Image 6.3

*Do not overtighten the hex lock nuts, the U-bracket has to be able to freely rotate

Jet size might have to be changed according to pump specifications (volume, GPM, and pressure)

SAFETY INSTRUCTIONS

WARNING!

To reduce the risk of fire, or injury follow these tips:

3. Keep away from children and animals. Do not use the extractor and/or attachment as a toy.
4. Use only as described in this manual. Use only manufacturer recommended parts.
9. Do not put any object into openings, only the items mentioned in the manual. Do not use with any opening blocked; keep free of dust, lint, hair and anything that may reduce the air flow.
10. Keep hair, loose clothing, fingers and all parts of body away from openings and moving parts.
11. Do not pick up anything that is burning or smoking, such as cigarettes, matches or hot ashes.
14. Use extra care when cleaning on stairs.
15. Always wear safety equipment and appropriate clothing when operating the attachment.
16. Do not use the attachment to pick up flammable or combustible liquids such as gasoline or use in areas where such combustible may be present.
18. Do not attempt to service the attachment while appliance is plugged in.

ATTACHMENT OVERVIEW

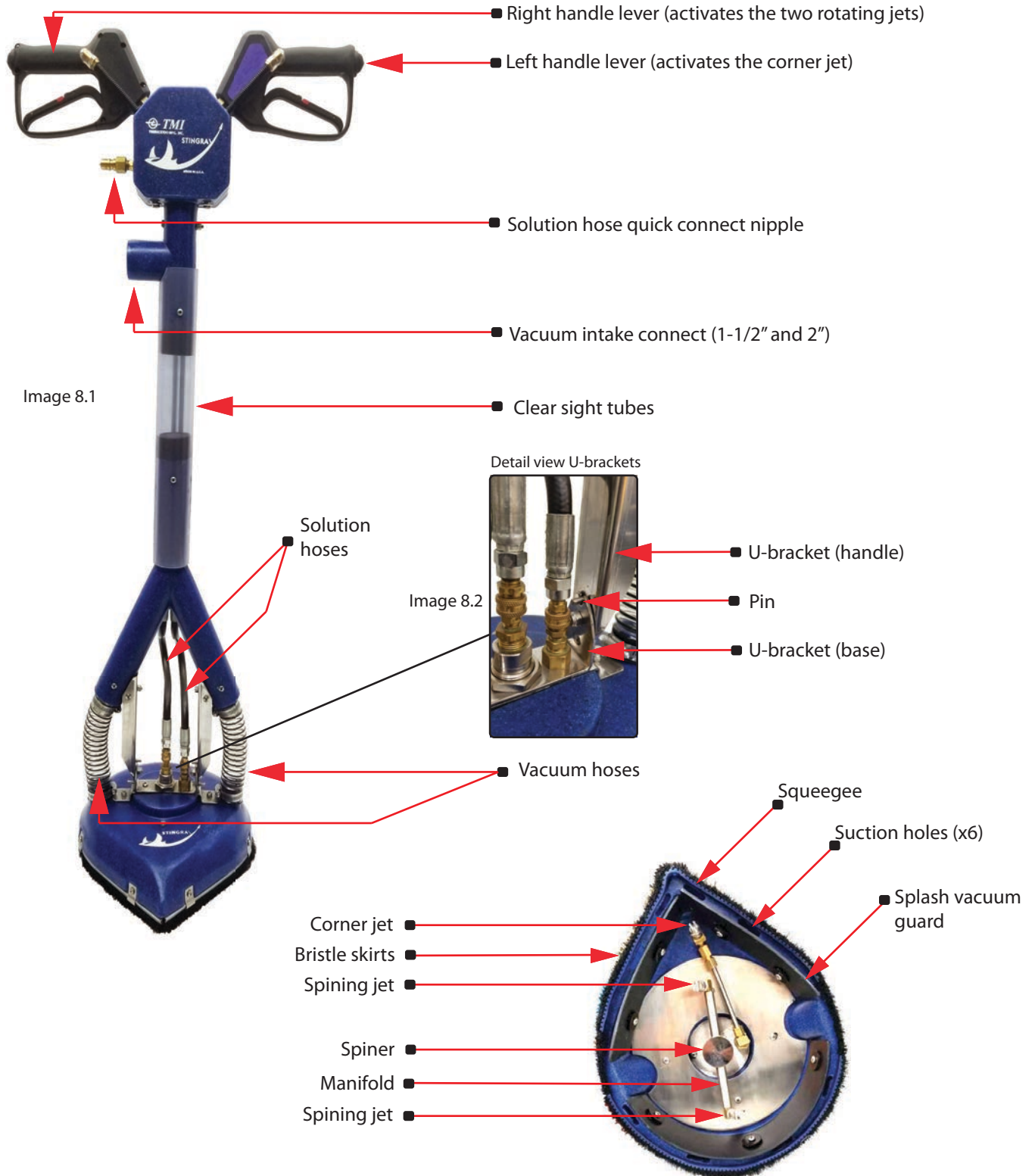

IMAGES AND ILLUSTRATIONS ARE FOR REFERENCE ONLY.
 ACTUAL PRODUCTS MAY NOT BE EXACTLY AS SHOWN.

Image 8.3

ATTACHMENT SET UP

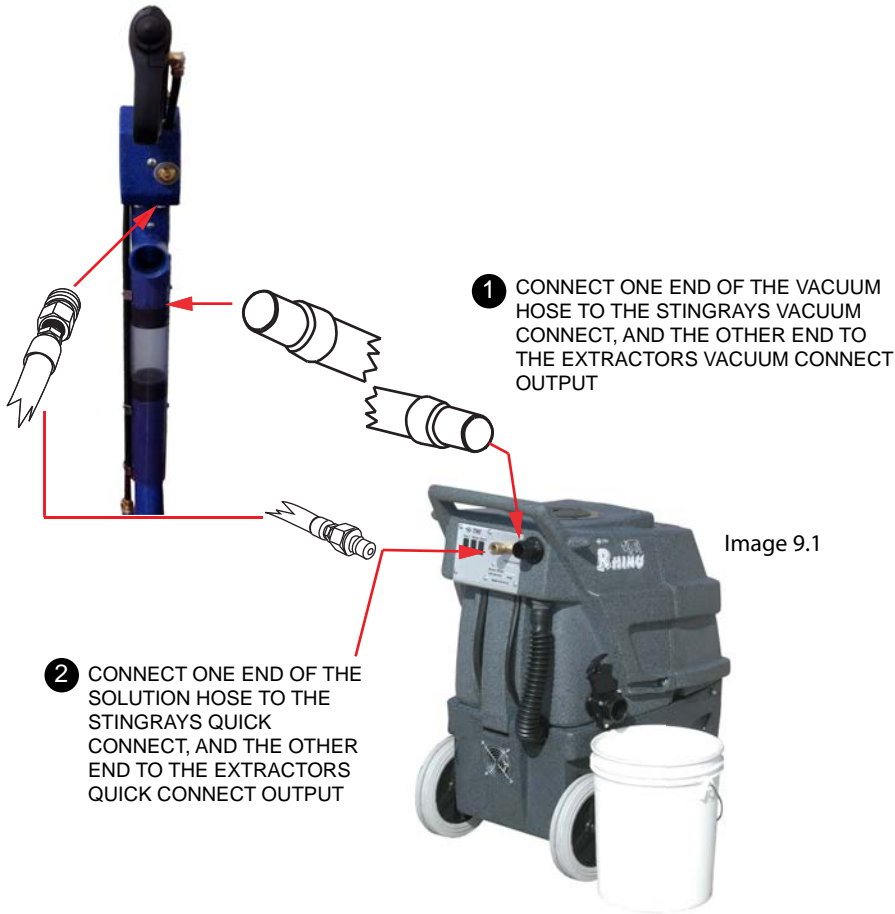

PREVENTATIVE MAINTENANCE

AFTER USE INSTRUCTIONS

Stingray maintenance requirements:

Like any quality tool, it does require some care to keep it in optimum working condition. Careful attention to these maintenance instructions will give you maximum operating performance and increase the life of your attachment tool.

1. Thoroughly clean all equipment and accessories after each use.
 - a. Rinse base/head chamber section, clean handle section, and hoses with clean water.
 - b. Flush entire solution system with clean water. This includes all solution hoses and tools. Do not allow liquid with cleaning chemicals to remain in the equipment.
 - c. Clean all filters of extractor or/and truck-mount.
2. Must rinse or clean after each use at base/head chamber section, outer and inner squeegee blade chamber, bottom cleaning chamber, brush, and jets to make sure free of debris.
3. Clean the solution jets. Remove the jets located at the ends of the manifold, located in the cleaning chamber of the base by turning the base section over to expose the underside. Carefully remove the two jets with a 9/16" open-end wrench; before removing the jets, note the position and angle at which they are set; you will need to replace them to the same positions after they have been cleaned or replaced. (Do not use hard metal objects or metal brushes) After cleaning is completed, reinstall the jets to the original and correct positions.
4. Occasionally, lubricate all quick connects. Every 3 months.
5. Keep equipment out of extreme temperatures. (i.e. Freezing temperatures will make water expand, and will damage fittings, valves, etc.)
6. Turn off the extractor and/or attachment tool when not in use. Especially, walking away from the extractor and/or attachment tool and not using it for a while may build up pressure in the extractor or attachment tool. This can cause excessive pressure that might damage the attachment tool or extractor.

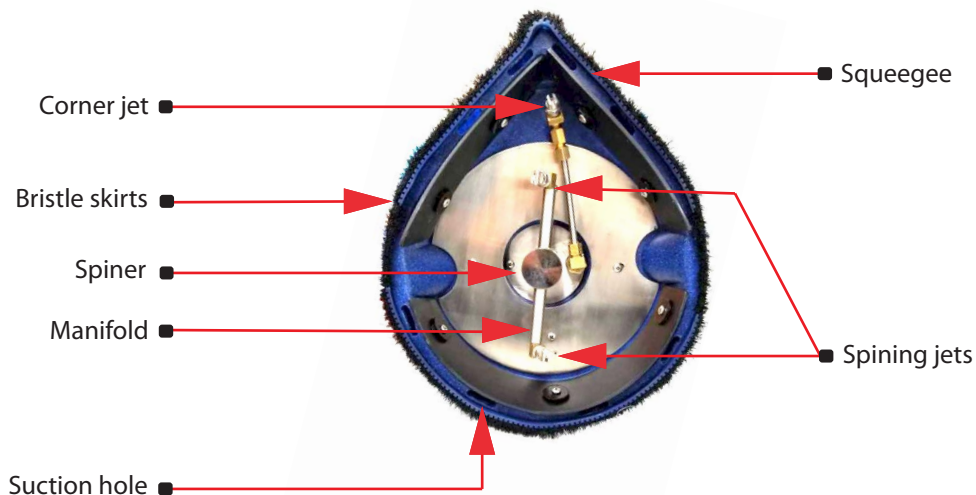

Image 10.1

OPERATING THE ATTACHMENT

Read the manual carefully and completely before attempting to operate the Stingray attachment.

The Stingray base is engineered and designed to use in horizontal position only, the handle can be vertically rotated for better maneuverability.

1. Sweep or vacuum any debris, or exposed objects on the surface to be cleaned.
2. Mask and tape the areas you want to protect (Cabinets, adjoining areas, walls, etc...)
3. Apply chemical solution (Grout cleaner, stripper, etc...) on surface to be cleaned by pre-spraying it with a spray applicator. Follow the directions on the solution label for dilution, and working time of the solution for best results.
4. Connect the TMI's Stingray attachment to an operating system. (Extractor, truckmount, etc...)
5. Set the correct pressure for the surface to be cleaned. (3000 PSI max).

CONNECT TO A TMI'S PORTABLE EXTRACTOR OR TRUCKMOUNT:

Connect your solution hose (quick connect) to the Stingray quick connect fitting and the vacuum cuff to the vacuum port (Image 11.1)



USE WITH TMI'S PORTABLE EXTRACTORS:

(See your TMI'S portable extractor owner's manual)

Adjust the pressure by opening the hand valve (spray lever) on the Stingray. With the hand valve open, adjust the manual pressure control knob (pressure regulator) on the TMI extractor to the correct setting for the surface or material that is going to be cleaned. When the correct pressure is set, release the hand valve.

USE WITH TMI'S TRUCKMOUNTS: (see your TMI Truckmount owner's manual)

Adjust pressure as per your specific equipment and surface condition. Not to exceed 3000 PSI.

HEAT: It is possible to use heat producing extractors up to 210 degrees.

OTHER: If not using a TMI brand portable extractor or truckmount, please check with TMI or TMI authorized dealer for compatibility.

OPERATING THE ATTACHMENT

General Technique:

1. Connect solution and vacuum hose
2. Unlock top handle assembly from the bottom base
3. Turn the portable extractor or truckmount on
4. Set up the extractor to the lowest pressure available, and slowly increase the pressure as desired depending on the type of surface.

It is recommended to start cleaning the edges and corners first, spraying with the corner jet, and then move on to the other open areas using the whole base with the rotating jets. Front part of the base is designed to clean corners and edges as shown in the picture below (image 12.1). The corner spray jet is activated by the left handle lever and the right jet is activated by the right handle lever. The whole base of the Stingray is usually used to clean larger areas.

Pull the attachment tool toward over the desired area. Repeat this process in both directions, using overlapping passes. To extract more solution from the surface release the handle valve levers, using only vacuum and remove excess solution. Continue this process until the pre-sprayed area has been cleaned. Try different techniques for the surface you are cleaning to achieve optimum results.

Upon completion, shut down operating system, release the pressure of Stingray by pressing the pressure handle valve (spray lever) and disconnect hoses from the handle section.

Call customer service for more information regarding cleaning methods.

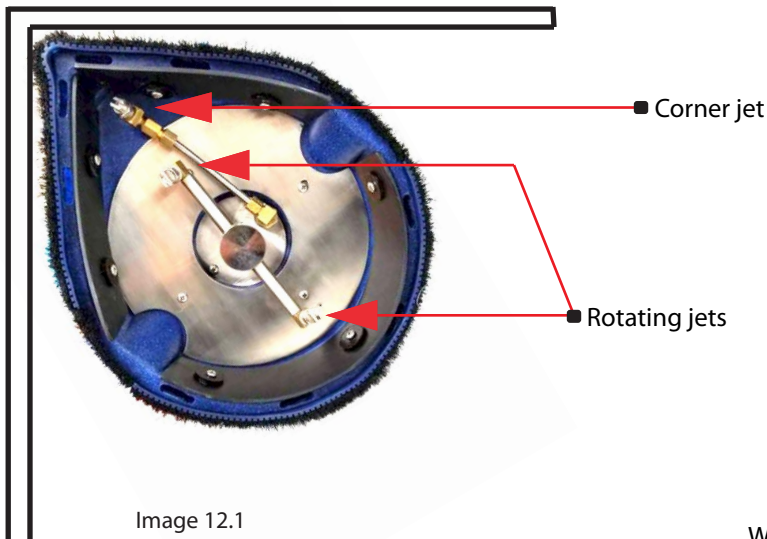

Image 12.1

Jet size might have to be changed according to pump specifications (volume, GPM, and pressure)

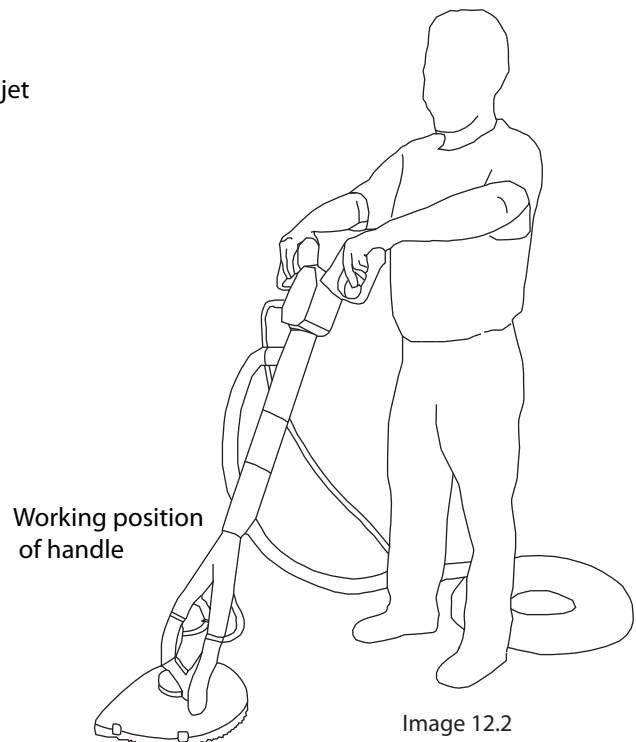

Image 12.2

TROUBLESHOOTING

ATTACHMENT		
Problem	Possible Cause	How to Repair
No water coming out from the jet	<ol style="list-style-type: none"> 1. Lever not pulled up 2. The hose is not connected properly 	<ol style="list-style-type: none"> 1. Pull up lever 3. Connect hose properly
Irregular spraying / not spraying	<ol style="list-style-type: none"> 1. Jets are clogged 	<ol style="list-style-type: none"> 1. Remove & clean w/vinegar. This eliminates calcium built up
Steaks on floor	<ol style="list-style-type: none"> 1. Squeegee blade has nick on it 2. To much chemical on sprayed 	<ol style="list-style-type: none"> 1. Remove squeegee blade 2. Mix chemical per Mfg. recommendation
No suction	<ol style="list-style-type: none"> 1. Suction holes are clogged 	<ol style="list-style-type: none"> 1. Clean suction holes
<p>DO NOT ATTEMPT TO REPAIR THE MACHINES, CONTACT AN AUTHORIZED REPAIR SHOP OR DEALER. DO NOT USE/TURN ON THE UNIT, WHEN THE UNIT IS UPSIDE DOWN OR SHOWING MOVING JETS/ARMS. DISCONNECT POWER CORDS FROM THE OUTLET BEFORE DOING ANY MAINTENANCE WORK.</p>		

BLANK PAGE