

**CleanFreak**  
(888) 722-5508

# **CleanFreak**

**CF-100 Series**

Model: CF-100  
Model: CF-100H

## **Portable Heavy Duty Extractor Owner's Manual**



**CleanFreak.com**  
P.O. Box 569  
Wausau, WI 54402  
Phone: 888-722-5508  
Local: 920-882-8453  
<http://www.cleanfreak.com>

© All Rights Reserved. 2008



**CleanFreak**  
(888) 722-5508

**Janitorial Equipment & Supplies**

## CAUTION

### When the machine is delivered

Check the carton and machine carefully for signs of rough handling. If the unit is damaged, notify the carrier immediately and request an inspection. Be sure to keep the carton, packing inserts, packing list and carrier's receipt until the inspector has verified your claim.

### General precautions

Make sure the machine is plugged into an electrical outlet with the same voltage as shown on the unit. When plugging in a two cable machine, each cable should be plugged into a **separate circuit**, when this is accomplished a "Green Light" will turn on in the dash panel. Push switch on dash panel above green bulb, if two circuits are accomplished the bulb will light up. No light,

### Warning

This extractor was designed for use on carpet, floor and upholstery applications as per instructions and recommendations written in this manual. Any deviation from its proper use or purpose and the consequential damage that may occur is the sole responsibility of the end user.

Do not use volatile substances such as gasoline, kerosene, or any petroleum based solvent in the machine or anywhere near the cleaning area. The use and presence of such materials could cause an explosion and fire.

Do not expose machine to extreme temperatures.  
Do not attempt repair of machine, contact CleanFreak.  
Do not use unauthorized replacement parts.

This extractor was tested before shipping. In most cases some water or anti freeze might remain in the plumbing system, we suggested flushing it out before using it. Make sure to use anti freeze for storage if you are located in extreme cold weather.

This extractor is being shipping with protective plastic wrap over the casters and wheels. Please remove the plastic wrap before use. Using without removing the protective plastic wrap may cause a jam or even lock up the wheels or casters. (see below)



1

protective plastic wrap

protective plastic wrap

## Trouble-Shooting cont.

Vacuum System		
Problem	Possible Cause	How to Repair
Heat doesn't come on	1. Air in the heater	1. Bleed
	2. Check reset-able thermostat on heater (see below image)	2. Re-set thermostat
	3. Check thermostat-it's either ON or OFF (see below image)	3. Re-set thermostat
	4. Heating element is burned out.	4. Contact service center
<b>CAUTION: when electric power is on protect yourself from electric shock &amp; heat</b>		



image #1

manual re-set bottom



image #2 (enlarge view)

manual re-set bottom

Disconnect Power Cords from the outlet before doing any maintenance work

## Trouble-Shooting cont.

<b>Vacuum System</b>		
Problem	Possible Cause	How to Repair
Vacuum motor on, little or no vacuum or suction to head (wand/upholstery tool)	1. Lid is not closed 2. Drain hose not connected 3. Hose or wand clogged 4. Accumulated dirt on the ball float cage and filter 5. Worn out lid gasket 6. Lint and dirt build-up on wand 7. Damaged vacuum hose 8. Loose or no vacuum hose connection inside the machine 9. Lint accumulation in vacuum fans	1. Close the lid 2. Connected hose 3. Clean hoses and wand 4. Clean or replace the filter 5. Replace the gasket 6. Clean the wand 7. Replace 8. Contact CleanFreak 9. Contact CleanFreak
Vacuum motors run intermittently		Contact CleanFreak
<b>ETC.....</b>		
Problem	Possible Cause	How to Repair
No water from the jet	1. Machine not plugged in (or circuit breaker off) 2. Switch is not turned on (bad switch?) 3. Empty solution tank 4. The hose is not connected properly	1. Plug in working outlet 2. Turn the switch on. Contact CleanFreak for new switch 3. Fill the solution tank with water 4. Connect hose properly
Water or foam coming out from exhaust	1. Over foaming of water in recovery tank 2. Elbow fitting in recovery tank pointing wrong direction (i.e. pointed toward the ball-float cage) 3. No ball-float cage 4. Too much water in the recovery tank	1. Put defoamer in the recovery tank or <u>put it in the end of vacuum hose with vac. motor running</u> 2. Point elbow away from ball-float cage 3. Install ball-float cage w/filter 4. Drain the recovery tank

**DO NOT ATTEMPT TO REPAIR MACHINES, CONTACT CleanFreak**

**Disconnect Power Cords from the outlet before doing any maintenance work**

## TABLE OF CONTENTS

Caution .....	1
Table of Contents .....	2
Owner's Warranty Information .....	2
Warranty .....	3
Warranty Registration Card .....	4
Safety Instructions .....	6
Extractor Overview .....	7
Assemble .....	8
Preventative Maintenance .....	8
Operating the Extractor .....	9
Blank Page .....	10
Extractor Inside .....	11
Trouble-Shooting .....	12
Trouble-Shooting Cont. ....	13
Trouble-Shooting Cont. ....	14

## Owner's Warranty Information

Date of Purchase: .....

Serial Number: .....

Model Number: .....

Purchased From[Dealer name]: .....

Address: .....

City, State, Zip: .....

Telephone: .....

Keep for your own records

## LIMITED WARRANTY

All equipment and accessories are thoroughly inspected and tested before leaving the factory. They are warranted to be free of defects from workmanship and material for one year from date of original purchase.

(Proof of purchase is required)

Should any trouble develop during this period, return the item, freight prepaid, to the factory with the factory issued RETURN AUTHORIZATION NUMBER (RAN) or authorization CleanFreak.com service center. If inspection shows the trouble to be caused by defective workmanship or material, the factory will repair (or at our option, replace) without charge, those items. If it is determined to be a warrantable repair the freight back will be pre paid by the factory. No credit will be allowed for items returned as defective without the above mentioned (RAN) number and the determination that it is defective.

Proof of purchase is necessary establishing the date of original sale. That should be the Registration & Receipt of "WARRANTY REGISTRATION CARD". It is extremely important to register your purchase by sending the card back within 10 days of purchase.

This warranty is in lieu of all other warranties expressed or implied and no person is authorized to give any other warranty, assume obligation or liability on the factory's behalf.

This warranty does not apply when:

- Repairs have been made or attempted by others
- Repairs are required because of normal or natural wear and tear
- Items have been abused, misused or improperly maintained
- Modifications or alterations have been made to the equipment

### LIMITATION OF REMEDY:

In no event shall seller be liable for any incidental, consequential or special damages of any kind or nature whatsoever. Including but not limited to lost profits arising from or in anyway connected with this agreement or items sold hereunder, whether alleged to arise from breach of contract, express or implied warranty, or in tort, including without limitation, negligence, failure to warn or strict liability.

### ENTIRE AGREEMENT / GOVERNING LAW:

This agreement and warranty shall be governed in all respects by the law of the State of Wisconsin. No actions arising out of the items sold hereunder or this Agreement may be brought by either party more than two (2) years after the cause of action occurs. All mediation or litigation will take place in the County of Marathon in Wisconsin.

## Trouble-Shooting

Electrical System		
Problem	Possible Cause	How to Repair
No electrical power	1. Check the outlet & the plug 2. Damaged cord  3. Circuit breaker off or fuse blown	1. Plug in properly 2. Contact CleanFreak  3. Flip circuit breaker on or replace fuse. Unplug other equipment using the same circuit. Make sure cords plugged into proper amp circuits.
Switch is turned on, power is intermittent to all motors	1. Faulty electrical cable 2. Defective switch 3. Loose terminal or corroded connector	1.to 3: Contact CleanFreak
Electric shock	1. Equipment not grounded	Contact CleanFreak
Pump System		
Problem	Possible Cause	How to Repair
Pump motor stopped	1. Pressure build - up  2. Thermal overload (overheated)  3. Damaged motor or rectifier 4. Pump switch defective 5. Loose wire connection 6. Pump pressure switch defective 7. Faulty motor	1. Release pressure by opening up (press) the lever on the wand 2. Turn off the pump and heater switch and wait 20 -30 minutes for the pump to cool down. 3. to 7: Contact CleanFreak
Loss of pump pressure with wand valve open and/or uneven or weak spray from the jet tips	1. Clogged or dirty spray- tip 2. Accumulated dirt in solution line 3. Dirty or clogged filters 4. Pump check valve worn or dirty 5. Malfunction in the wand valve 6. Hose quick connect bad or clogged with lint.	1. Clean jets and screens 2. Clean 3. Clean 4. to 6: Contact CleanFreak

# MACHINE INSIDE VIEW

solution/recovery tank latching bolt  
housing latching bolt



right and left housing latching bolts for open housing section



CF-100



CF-100 inside (without heater)

heater (2)  
heater quick connect (2)



CF-100H inside (quick connect with heater)

## WARRANTY REGISTRATION

PLEASE PRINT OR TYPE

**PURCHASED FROM:** .....

**ADDRESS:** .....

**DATE PURCHASED:** .....

**PURCHASER'S NAME:** .....

**ADDRESS:** .....

**TEL:(     )** .....

**MODEL NO:** .....

**SERIAL NO:** .....



*CUSTOMER RECORDS*

## AUTHORIZED CleanFreak.com CENTER

### WARRANTY REGISTRATION

PLEASE PRINT OR TYPE

**DEALER:** .....

**ADDRESS:** .....

**DATE SOLD:** .....

**PURCHASER'S NAME:** .....

**ADDRESS:** .....

**TEL:(     )** .....

**MODEL NO:** .....

**SERIAL NO:** .....

**Signature:** .....

**Print Name:** .....





Mailing Address:  
CleanFreak.com  
*P.O. Box 569*  
**Wausau, WI 54402**

## OPERATING THE MACHINE

Read the manual carefully and completely before attempting to operate the unit. Make sure the unit is plugged into an electrical outlet with the same voltage as shown on the unit.

1. When plugging in a **two cable** machine; (2)-**two distinct circuits must be used.**  
**To ensure you have two separate circuits we have installed a switch labeled "CIRCUIT TEST" or "TEST SWITCH" or "TWO CIRCUIT TEST SWITCH" right next to the green light. Push that switch and the green light should glow---if not you don't have two separate circuits. Keep looking and do not turn the machine on as you may "BLOW" a single circuit.**
2. Always thoroughly vacuum the surface to be cleaned. Using an upright vacuum cleaner or the extractors dry vacuum with optional dry attachment.
3. Pre Vacuum the area to be cleaned with a dry vacuum cleaner or upright vacuum.
4. Recommended method of applying chemicals to the floor is to **pre spray the cleaning area with recommended cleaning solution.**  
This will give it time to do it's job and result is a much cleaner floor.
5. We do not recommend putting chemicals in the machine's tank. Fill solution tank with clean water (use cool water for wool).
6. Make sure drain valve is closed and recovery tank lid are closed before turning on vacuum and pump switches. (If left open, there will be no suction)
7. Make sure drain hose is connected and recovery tank lid are closed before turning on vacuum and pump switches. (if left open, there will be no suction)  
**This applies only to extractors with and optional auto dump system.**
8. **In case foam is detected in recovery tank and hose, use defoamer to prevent damage to the vacuum motors.**
9. Continue cleaning until the clean water tank is empty and/or recovery tank is full (or until cleaning job is done). Turn off all the switches and disconnect power cord from power plug, then empty the recovery tank into a bucket or another proper drain area.
10. To remove remaining water from clean water tank, disconnect the vacuum hose from wand and insert the vacuum hose into clean water tank. Vacuum out all the excess water. Drain and thoroughly clean the recovery tank.  
At this point the tank can be rinsed while dumping.
11. The vacuum filter (wet filter) and ball float cage have to be rinsed and cleaned thoroughly when it's still wet. Wrap power cords around handle for storage. Do not use solution or recovery tanks for storage, machine can be damaged.

Consult your sales representative for more information on cleaning methods.

## SAFETY INSTRUCTIONS

### Read All Instructions Before Using This Extractor

When using an electrical appliance, basic precautions should always be followed.

#### WARNING - To reduce the risk of fire, electric shock or injury:

1. Do not leave appliance plugged in. Unplug from outlet when not in use and before servicing.
2. WARNING: ELECTRIC SHOCK COULD OCCUR IF USED OUTDOORS OR ON WET SURFACES.
3. Do not allow to be used as a toy. Close attention is necessary when used by or near children.
4. Use only as described in this manual. Use only manufacturer's recommended parts.
5. Do not use with damaged cord or plug. If appliance is not working as it should, has been dropped, damaged, left outdoors or dropped into water, follow warranty instructions and contact an approved service center.
6. Do not pull or carry by cord, do not use cord as a handle, do not close a door on cord, or do not pull cord around sharp edges or corners. Do not run appliance over cord. Keep cord away from heated surfaces.
7. Do not unplug by pulling on cord. To unplug, grasp the plug, not the cord.
8. Do not handle plug or appliance with wet hands.
9. Do not put any object into openings. Do not use with any opening blocked; keep free of dust, lint, hair and anything that may reduce air flow.
10. Keep hair, loose clothing, fingers and all parts of body away from openings and moving parts.
11. Do not pick up anything that is burning or smoking, such as cigarettes, matches or hot ashes.
12. Do not use without filters in place.
13. Turn off all controls before unplugging.
14. Use extra care when cleaning on stairs.
15. Always wear safety equipment and appropriate clothing when operating extractor to protect from hot water.
16. Do not use machine pick up flammable or combustible liquids such as gasoline or use in areas where they may be present.
17. Connect to a properly grounded outlet only.
18. Do not attempt to service the unit while appliance is plugged in.

## MACHINE OVERVIEW

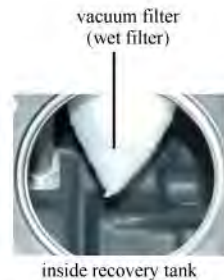

## ASSEMBLY

1. Connect vacuum hose to vacuum intake connection on the machine and the wand, solution hose to the solution connection (solution outlet to quick connector on wand).
2. To protect the grounding plug; this plug is to be used only with a proper grounding type (three prong) receptacle. Do not break off or pull out the grounding blade. (see A-1, P.8)

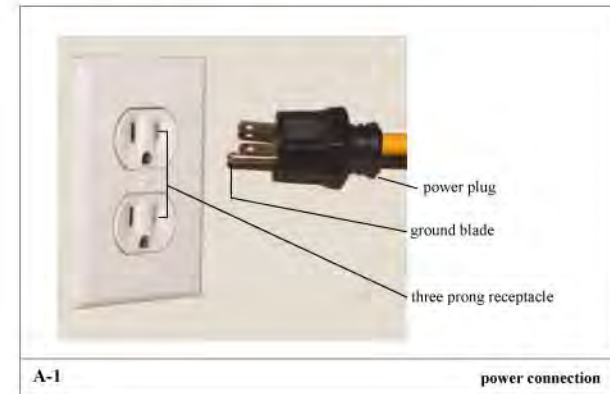

## PREVENTATIVE MAINTENANCE

1. **Thoroughly clean all equipment and accessories after each use.**
  - a) **Rinse solution and vacuum tank with clean water.**
  - b) **Flush entire solution system with clean water. This includes all solution hoses and wand(s). Do not allow liquid with cleaning chemicals to remain in the equipment.**
  - c) Clean all filters.
2. Occasionally, lubricate all quick connects. (every 3 months)
3. Do not use the same pail to fill the solution tank that is used to empty the waste tank.  
This would result in putting dirt and debris into the solution lines that can block filters, orifices, and generally degrade solution line systems.
4. Keep equipment out of extreme temperatures. (i.e. Freezing temperatures will make water expand, and will damage pump, fittings, valves, etc.)
5. **Turn off the machine when not in use. Especially, walking away from the machine and not using it for a while may build up pressure in the machine or heater. This can cause excessive pressure that is not good for the machine.**
6. Check for loose or frayed wires.



CF-100 SERIES  
housing page

2-2 vac motors  
100-120 psi

feb1111

CF

CleanFreak

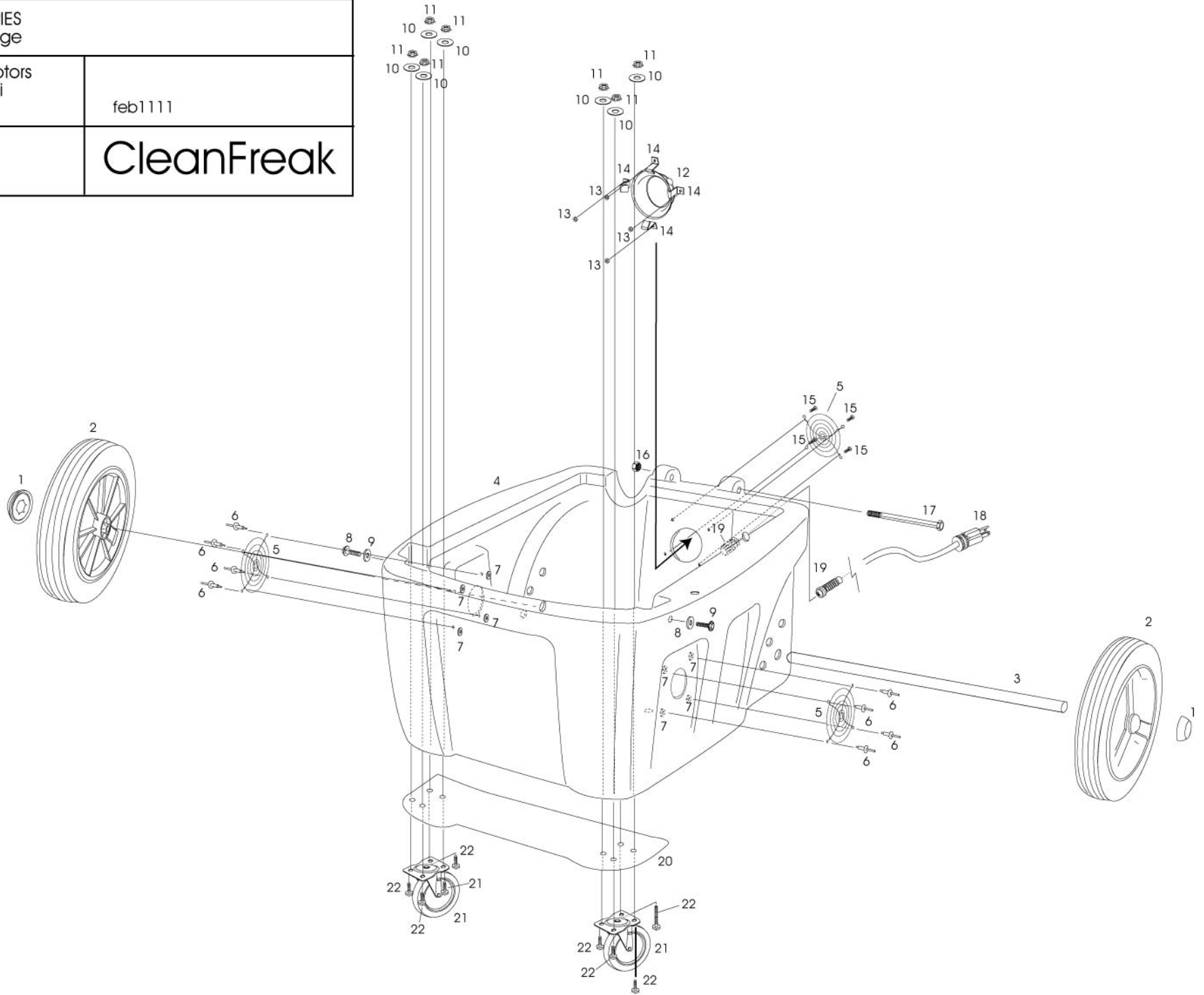

CF 100 SERIES  
 BOTTOM HOUSING  
 2-2stg VAC MOTORS  
 100 OR 150 PSI

ITEM No.	PARTS LIST	QTY	DESCRIPTION
1	FS07108	2	1/2" AXLE (ROD) END CAP
2	WC161094	2	10X1.75X1/2"NONMARKIWHEEL80CAB
3	FS05081808	1	AXLE(ROD)1/2" X 18-1/2"
4	TC13330895	1	RHINO BASE - GRANITE
5	TE438134	3	COOLING FAN SCREEN
6	FR03604	8	AL/ST 6-4 RIVET
7	FW302316	8	3/16 ALUM. RIVET WASHER AS6R
8	FB023416	2	1/4-20x1 HEX TAPTITE BOLT-ZINC
9	FW552400	2	1/4 PLASTIC CUT WASHER
10	FW302424	8	1/4X1-1/4 ZINC FENDER WASHER
11	FN1020421	8	1/4X20 KEPS NUT
12	TMC6225	1	RHINO EXHAUST
13	FN1021032	5	10X32 KEPS NUT ZINC
14	TP110480	4	RHINO EXHAUST HOLDING BRACKET
15	FB1032116	5	10-32X1 PH.PAN HEAD ZN
16	FN1141616	1	3/8 x 16 CENTER LOCK NUT ZN
17	FB022688	1	3/8-16x5-1/2 HEX BOLT-ZINC
18	TE101230	1	12-3SJTW-A POW.CORDX25"W/15M.P
19	TE101500	1	CORD RETAINER (COMPLETE)
20	TMC6228	1	RHINO BASE REINFORCE PLATE
21	FB022416	2	1/4-20 x 1 HEX BOLT-ZINC
22	FB022412	6	1/4-20 x 3/4 HEX BOLT-ZINC
23	WC120263	2	3"X1"NON MARKING SWIVEL CAST.*

CF-100 SERIES  
housing page

2-2 vac motors  
100-120 psi

feb1111

CF

CleanFreak

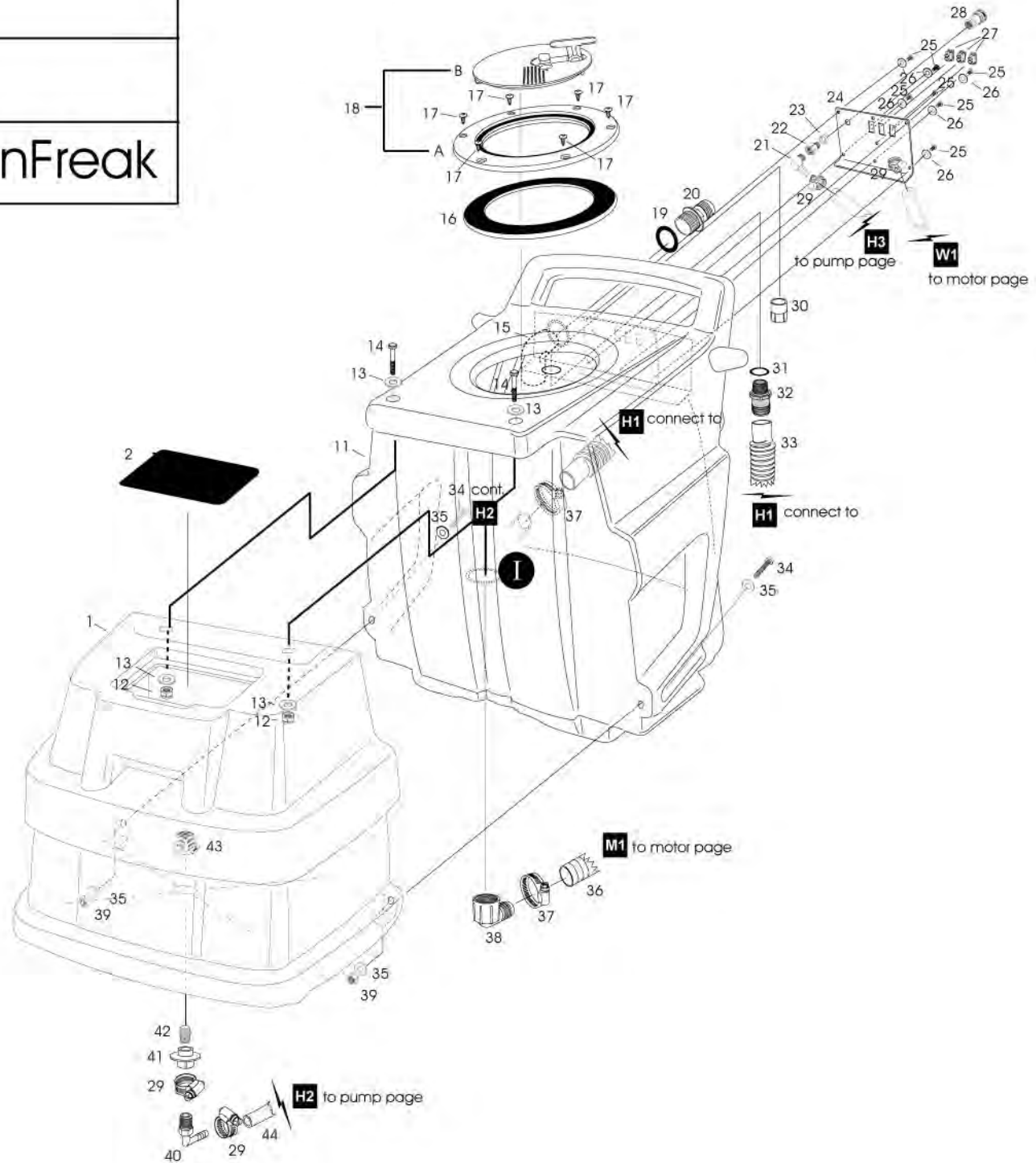
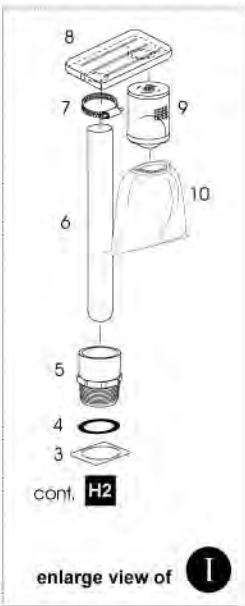



CF 100 SERIES  
 SOLUTION TANK AND RECOVERY TANK PAGE  
 2-2stg VAC MOTORS  
 100 OR 150 PSI

ITEM No.	PARTS LIST	QTY	DESCRIPTION
1	TC13320695	1	RHINO SOLUTION TANK - GRANITE
2	TMC6131	1	RHINO SOLUTION TANK LID
3	TPW20820	1	STAND PIPE BASE S/S WASHER 2-1
4	TB231602	1	1-1/2" X 3/16GASKET(THICK)
5	TB436212	1	REDUCING/M ADT1-1/2MPTx1-1/4SO
6	PM2320164	1	STAND PIPE 2"O.D.#G (16-1/2")
7	ID67321	1	1/2 SS BN,SS, 1-9/16 TO 2-1/2
8	PM10142	1	BALL FLOAT DUCT ONLY
9	PM10144	1	BALL FLOAT CAGE W/BALL
10	PM10155	1	VACUUM FILTER (BALL-FLOAT) - 4 filters/pack
11	TC13311795	1	RHINO RECOVERY TANK -GRANITE
12	FN1110420	2	1/4X20 S/S NYLON LOCK NUT
13	FW302300	4	1/4 S/S U.S.S. CUT WASHER
14	FB021428	2	1/4-20X1-3/4 HEX BOLT 18-8 S/S
15	TB231715	1	90DEG.ELBOW 1.5SPIG X 1.5FPT
16	DB10116	1	MOBIL LASTIC TAPE 1/16X1FT.
17	FB9010808	6	#8-18 x1/2 TRUSS PHIL SCREW S/
18	TMC6010	1	RHINO REC. TANK LID COMPLETE
	b TMC6011	1	RHINO REC. TANK LID ONLY
19	TB231601	1	1-1/2" X 1/8 GASKET(THIN)
20	TB231516	1	1.5"HOSE BARB W/FLANGE BLACK
21	129HB44	1	90 DEG. HB (HOSE X MPT)1/4X1/4
22	222P44	1	ADAPTER 1/4MPTX1/4FPT
23	FW552910	1	9/16 PLASTIC CUT WASHER
24	TMC6203	1	RHINO SWITCH PLATE W/3 CUT OUT
25	FB1032108	7	10-32X1/2PH.PAN HEAD ZN
26	FW302316	6	3/16 ALUM. RIVET WASHER AS6R
27	TE202012	3	CV/ON-OFF ROCKER SWITCH (TMI)
28	BH2-6020	1	BRASS COUPLER 1/4"FPT -FST
29	ID57060	4	H.C.1/2 SS BN,PLT,3/8TO7/8
30	TB435010	1	1" FEMALE ADAPTER x SLIP

31	<b>MS30G322</b>	1	O-RING FOR RHINO
32	<b>TB436133</b>	1	1-1/2" HOSE BARB x 1" MPT
33	<b>THD150016</b>	1	1.5"x16" DRAIN TUBE
34	<b>FB022424</b>	2	1/4-20X1-1/2 HEX BOLT-ZINC
35	<b>FW302400</b>	4	1/4 U.S.S. CUT WASHER ZINC
36	<b>TV151194-27</b>	1	1-1/2" WIRE BRAID INTRNL VAC H
37	<b>ID57200</b>	1	1/2 SS BN5/16PLT, 3/4 TO 1-3/4
38	<b>TB261510</b>	1	1-1/2" 90 DEG.HOSE BARBx1.5FPT
39	<b>FN1020421</b>	2	1/4X20 KEPS NUT
40	<b>N6MEB4</b>	1	90DEG.H.B.3/8HOSEX1/4MPT WH.NY
41	<b>TSP10402</b>	1	1/4FPTx1/4FPT SPIN FITTING
42	<b>215PN4</b>	1	CLOSE NIPPLE 1/4
43	<b>TF101050</b>	1	FILTER SCREEN S/S 50MESH 1/4FT

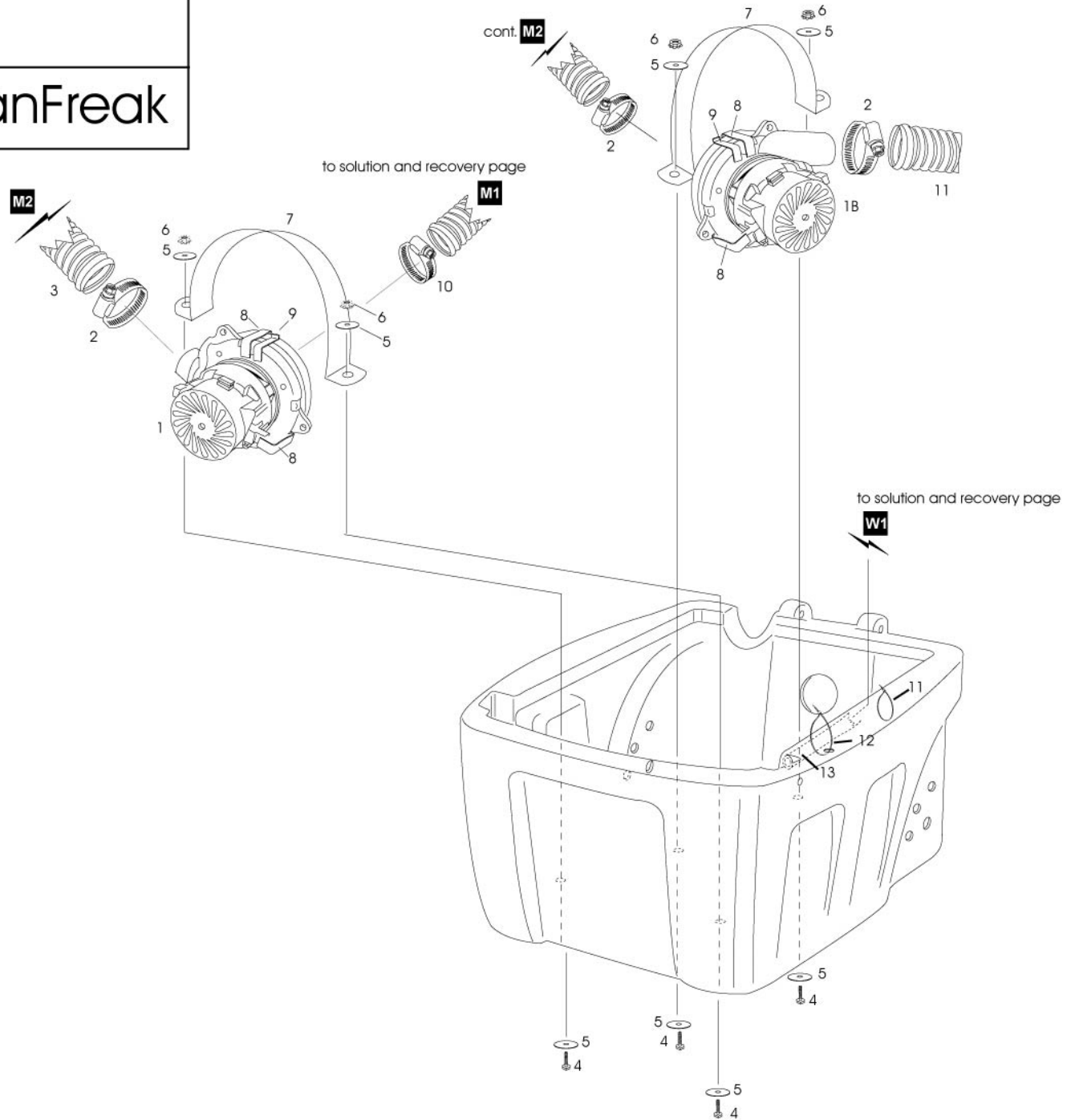
CF-100 SERIES motor page	
2-2 vac motors 100-120 psi	feb1111
CF	CleanFreak



- USE:**
-  Total 8 large zip tie (12)
  -  Total 6 small zip tie (11)

CF 100 SERIES  
MOTOR PAGE  
2-2stg VAC MOTOR  
100 OR 150 PSI

ITEM No.	PARTS No.	QTY	DESCRIPTION
1	<b>11660033-A/C</b>	1	120V/5.7 2STG 93" W/STRG ADAP
b	<b>11660033-C/C</b>	1	120V/5.7 2STG 93" W/1.5" STRA
2	<b>ID57320</b>	3	1/2 SS BN,PLT, 1-9/16 TO 2-1/2
3	<b>TV200294-18</b>	1	2" VACUUM HOSE x 18"
4	<b>FB022412</b>	4	1/4-20X3/4 HEX BOLT-ZINC
5	<b>FW302424</b>	8	1/4X1-1/4 ZINC FENDER WASHER
6	<b>FN1020421</b>	4	1/4X20 KEPS NUT
7	TP201211	2	MOTOR STRAP HOLDING BRACKET
8	<b>TP400401</b>	4	MOTOR CLAMP 5.7-2 STAGE MOTOR
9	<b>TP400405</b>	2	VAC STRAP GUARD
10	<b>ID57200</b>	1	1/2 SS BN5/16PLT, 3/4 TO 1-3/4
11	<b>TV151194</b>	1	1-1/2" WIRE BRAID INTERNAL VACUUM HOSE GRAY
12	<b>FT010204BLK</b>	4	HOSE TIE SOLID 4" BLACK
13	<b>FT010112</b>	12	HOSE TIE BLACK 11" LADDER
14	<b>TH3630899-38</b>	1	3/8"SOLUTION HOSE x 38"

CF-100 SERIES  
pump page

2-2 vac motors  
100-120 psi

feb1111

CF

CleanFreak

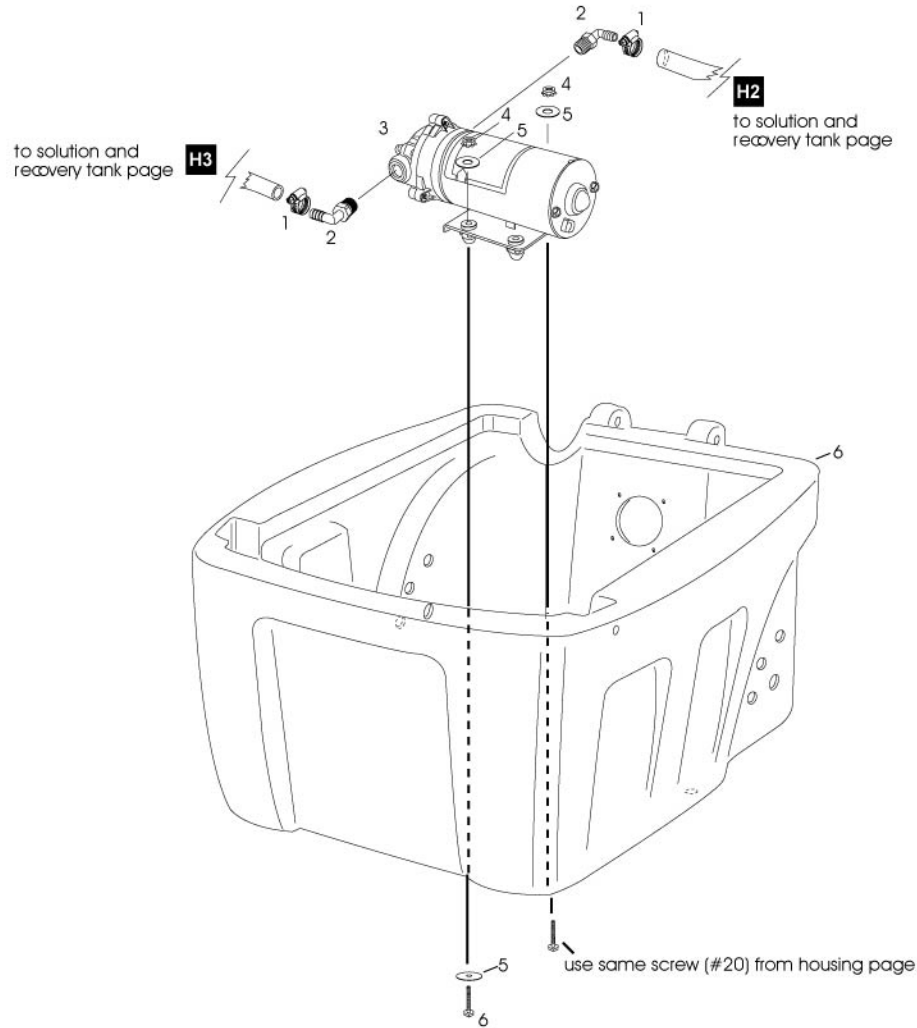



CF 100 SERIES  
PUMP PAGE  
2-2stg VAC MOTOR  
100 OR 150 PSI

ITEM No.	PARTS No.	QTY	DESCRIPTION
1	<b>ID57060</b>	2	H.C. 1/2 SS BN,PLT,3/8TO7/8
2	<b>N6MCB6</b>	2	HOSE BARB3/8HOSEX3/8MPT WH.NY
3	<b>S80812288</b>	1	115V100PSI/MITON/INT80PSIBYPAS
4	<b>FN1020421</b>	2	1/4X20 KEPS NUT
5	<b>FW302400</b>	3	1/4 U.S.S. CUT WASHER ZINC
6	<b>FB022424</b>	1	1/4-20X1-1/2 HEX BOLT-ZINC