

CleanFreak
(888) 722-5508

CF-3-H CleanFreak Spotter
3-Gallon Carpet Spot Extractor
with In-Line Heater
100 CFM / 804 Watt Motor



Owner's Manual

Important Information and Safety Instructions
PLEASE READ BEFORE USE!





CF-3-H CleanFreak Spotter

3-Gallon Carpet Spot Extractor
with In-Line Heater
100 CFM / 804 Watt Motor

Dear Customer,

Congratulations on your purchase of your Carpet Spot Extractor carpet and upholstery machine. The world of carpet cleaning is becoming more high-tech and competitive and we strive to provide you with the most innovative products. Our Carpet Spot Extractor is yet another example of this, bringing a new dimension to carpet and upholstery cleaning with its cutting-edge features, quality and design.

Please review this manual, paying careful attention to the Safety Instructions section. Keep in mind that any unnecessary damage, neglect or abuse of this machine will void your warranty. You can be confident that simple maintenance will ensure that your extractor provides quality performance for many years to come.

If warranty questions arise, please consult your manual or contact your distributor. Should you have any questions regarding maintenance, replacing parts or ordering parts, please call an authorized distributor.

Before you begin using your extractor, please thoroughly review the Owner's Manual. Again, congratulations on your purchase of your Carpet Spot Extractor.



CF-3-H CleanFreak Spotter

3-Gallon Carpet Spot Extractor
with In-Line Heater
100 CFM / 804 Watt Motor

TABLE OF CONTENTS

Warranty Information.....	2
Return Material Authorization Procedure (RMA).....	3
Safety Instructions.....	4
Preparing Your Unit for Use.....	4
Problem Solving.....	5
Wiring Diagram.....	6
Machine Schematic.....	7
Machine Parts Breakdown.....	8
Hose and Hand Tool Schematic and Parts Breakdown.....	9



CF-3-H CleanFreak Spotter

3-Gallon Carpet Spot Extractor
with In-Line Heater
100 CFM / 804 Watt Motor

WARRANTY

CleanFreak warrants your machine to be free of manufacture defects. CleanFreak will either repair or replace, at CleanFreak's discretion, the part/machine in question.

The warranty is as follows:

1. Molded Components.....5 Years
2. Vacuum Motor.....5 Years
3. Pump.....5 Years
4. Electrical Components.....5 Years

The manufacturer provides high-quality products and product support to its customers and stands behind all new products purchased. This warranty begins on the customer's purchase date and is valid and available to the original purchaser only. Other than set forth herein, the manufacturer gives no warranty, expressed or implied, as to description, quality merchantability, fitness for any particular purpose, productiveness, infringement, or other matter of any goods which the manufacturer shall supply. There are no warranties which extend beyond the description on the face hereof. The manufacturer shall in no way be responsible for the improper use and application of goods. The manufacturer neither assumes nor authorizes any other person to assume for the manufacturer any other liability in connection with the sale of the manufacturer goods. This warranty policy may be changed or withdrawn by the manufacturer at any time.

Limitation of damages: The remedy of replacement or repair of any defective goods shall be the exclusive remedy under any warranty made by the manufacturer, whether expressed or implied. In no event shall the manufacturer be liable for any incidental or consequential damages, property damages or personal injuries.

All warranties are void, for the manufacturer does not warrant in any way, any product that evidences misapplication, improper installation, abuse, lack of maintenance, negligence in use or case, abnormal use, alteration design, use of incompatible or corrosive chemicals, use in a rental service, and/or servicing, installation or parts, or repairs by anyone other than the manufacturer or a manufacturer-authorized distributor or service center. The manufacturer may make changes in products it manufactures and markets at any time; these changes are made without obligation to chance, re-profit or upgrade any product previously sold or manufactured.

The manufacturer has no obligation to honor this warranty as set forth herein unless the original purchaser, promptly upon discovering the warranty claim prior to continuing to use the product, contacts the manufacturer or a manufacturer-authorized distributor or service center to describe the claim and to receive and follow instructions for documenting and resolving the claim. In addition, the purchaser must provide the product to which the claim applies to the manufacturer or manufacturer-authorized distributor or service center for a thorough inspection.



CF-3-H CleanFreak Spotter

3-Gallon Carpet Spot Extractor
with In-Line Heater
100 CFM / 804 Watt Motor

WARRANTY CONTINUED

If any provisions or portion of this warranty policy is found to be unenforceable, then the remaining provisions and portions shall remain valid and enforceable. If any provision of this warranty is found to be limited by law, then that provision or portion shall be construed to make it effective within the bounds of the law. For example, if there are legal limitations on the duration of warranties, the warranties made herein shall be construed to have the minimum duration required by the law, or, if there are legal limitations of exclusion of remedies, the exclusion made herein shall be construed to apply to the fullest extent possible without violating the law.

The validity, construction and performance of this warranty policy shall be governed by the laws of the State of California, without respect to conflicts of laws principles. The exclusive jurisdiction or any legal action arising from or related to this warranty policy shall be in the State of California and no legal action shall be commenced elsewhere.

RETURNED MATERIAL AUTHORIZATION (RMA) PROCEDURE

It is the responsibility of any Authorized Service Center (ASC) or distributor with written authorization to ensure that the customer's equipment is repaired as soon as possible. If a distributor does not have the facilities to repair the equipment, it may be shipped back to CleanFreak, or to any one of the manufacturer's Authorized Service Centers for repair. Only the manufacturer or its authorized dealers with written authorization, service centers and agents may make warranty repairs on this product. *All others do so at their own risk and expense, and upon doing so, void their warranty on this product.*

The distributor must follow the following manufacturer's standard RMA procedures:

1. All defective parts must be returned to CleanFreak with the proper documentation for evaluation at the customer's expense. This shipping is nonrefundable. All warranty claims are subject to an evaluation by the manufacturer to determine if warranty will be approved. Any credit or repair and/or parts will be issued only upon the evaluation and approval from the manufacturer.
2. When warranty is approved, the account will be credited for the replacement part(s) that were pre-purchased. If no replacement parts were pre-purchased, the warranted parts will then be shipped out. The manufacturer will ship these warranted replacement part(s) out prepaid. If warranty is denied, the account will not be credited for any parts accompanying the claim.



CF-3-H CleanFreak Spotter

3-Gallon Carpet Spot Extractor
with In-Line Heater
100 CFM / 804 Watt Motor

IMPORTANT SAFETY INSTRUCTIONS PLEASE READ AND SAVE! WARNING!

Follow these basic precautions when using your Carpet Spot Extractor:

1. Do not operate this unit if any part of the unit appears **damaged**.
2. Do not operate if **ground plug** is broken.
3. Do not operate if the unit is in **standing water**.
4. Do not use **volatile substances** or operate when volatile substances exist.
5. Do not service while unit is running or connected to electricity. **Unplug the unit!**
6. Do not use water more than **120 degrees Fahrenheit**.
7. Do not use **solvents** with this unit.
8. Do not use as a **dry vacuum**.
9. Do not use unit unless **completely assembled**.
10. Use only **liquid detergents**. Powders do not fully dissolve and damage motor.
11. Always use **defoamer**. Foam will suspend moisture particles that damage motor.

PREPARE UNIT FOR USE

1. All extractors—no matter what the time of year—are shipped with antifreeze in the pump and solution lines. *Prior to first use, fill the tank with one quart of warm water. Attached the hoses and using the hand tool, flush out the system by spraying the one quart of water through the pump.*
2. Attach the 1-1/2 inch vacuum hose and the brass quick disconnect.
3. Fill the base unit (the recovery tank must be removed) with warm water (less than 100 degrees Fahrenheit). Fill to approximately 4 inches from the top. Use a liquid detergent made for carpet cleaning or upholstery. Read and mix to the dilution ratios as directed.



CF-3-H CleanFreak Spotter

3-Gallon Carpet Spot Extractor
with In-Line Heater
100 CFM / 804 Watt Motor

PREPARE UNIT FOR USE – CONTINUED

Vacuum Shut-Off

The Carpet Spot Extractor is designed with a vacuum restrictor to reduce the vacuum when the recovery tank is full. When the vacuum is restricted, the liquid will not travel up the nozzle of the hand tool. The motor speeds up (the sound of the motor will change) and this is your warning to dispose of recovered solution. The restrictor is a foam float that slides up and down the vacuum tube in the recovery tank as shown in the photo on the right.



Following Each Use

Remove the vacuum hose from the upper body, unclip, rotate latch on the back of the unit and remove the upper section of the spotter. Dispose of the used solution by pouring the solution out of the vacuum inlet (not the hatch cover) into the toilet or janitor's closet sink.



PROBLEM SOLVING

Extractor will not run:

1. Check power connection. Move the grounded plug to an outlet that is working. Verify that the plug is working by plugging it into another electrical component, such as a lamp, hair dryer or drill.
2. Inspect the power cord for damage and replace if damage is found.

Loss of vacuum:

1. Make sure the float is at the bottom of the unit. Open the screw cap and push the float down.
2. Check that the hose cuff is securely attached to the front of the spotter.

Loss of solution pressure:

1. Verify that the pump is on.
2. Remove jet from end of hand tool and press trigger on wand.
3. Clean the solution intake in the solution tank.
4. Check the quick-disconnect for debris.
5. If the pump is still not working, contact your dealer.

SPOT EXTACTOR

Wiring Diagram

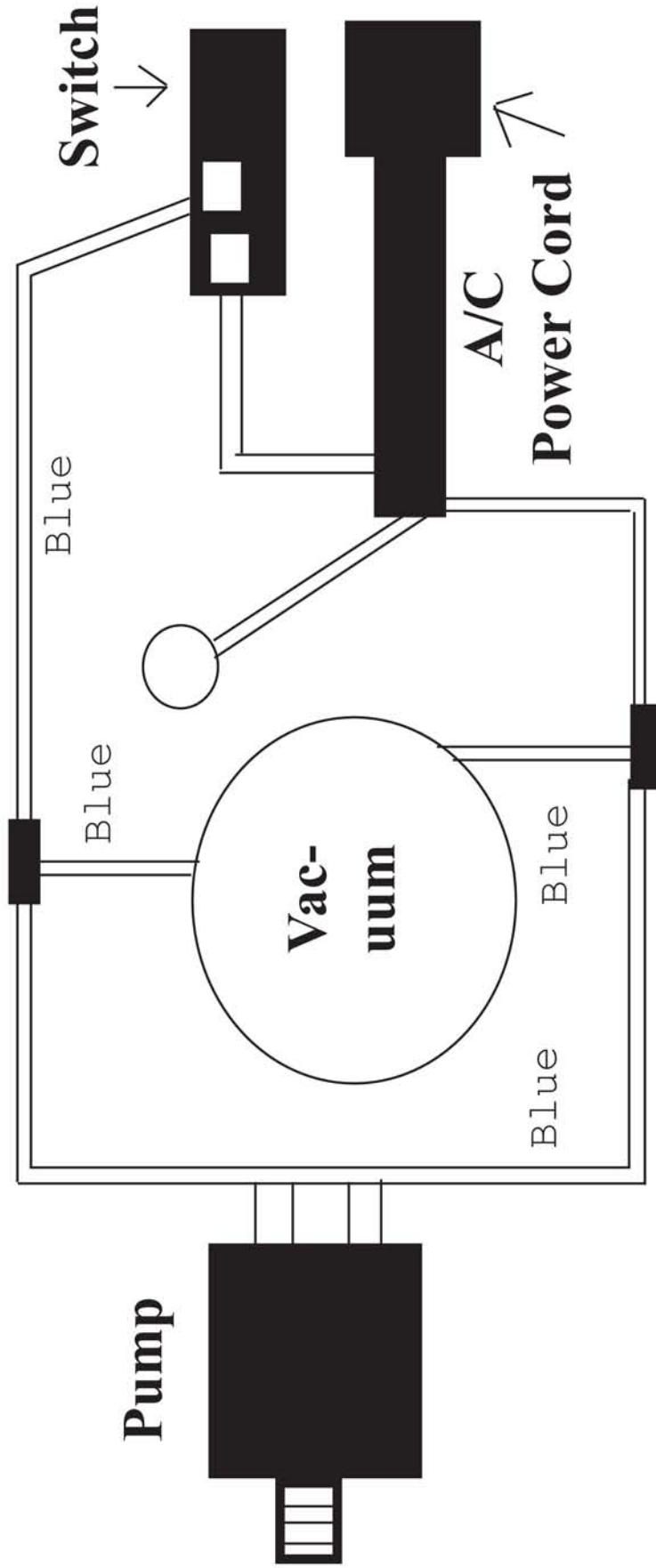

Caution: Color of the electrical wire may vary.

Determine the starting and ending point of each wire to confirm it's connection point.



CF-3-H CleanFreak Spotter

3-Gallon Carpet Spot Extractor
with In-Line Heater

100 CFM / 804 Watt Motor

MACHINE SCHEMATIC DRAWING

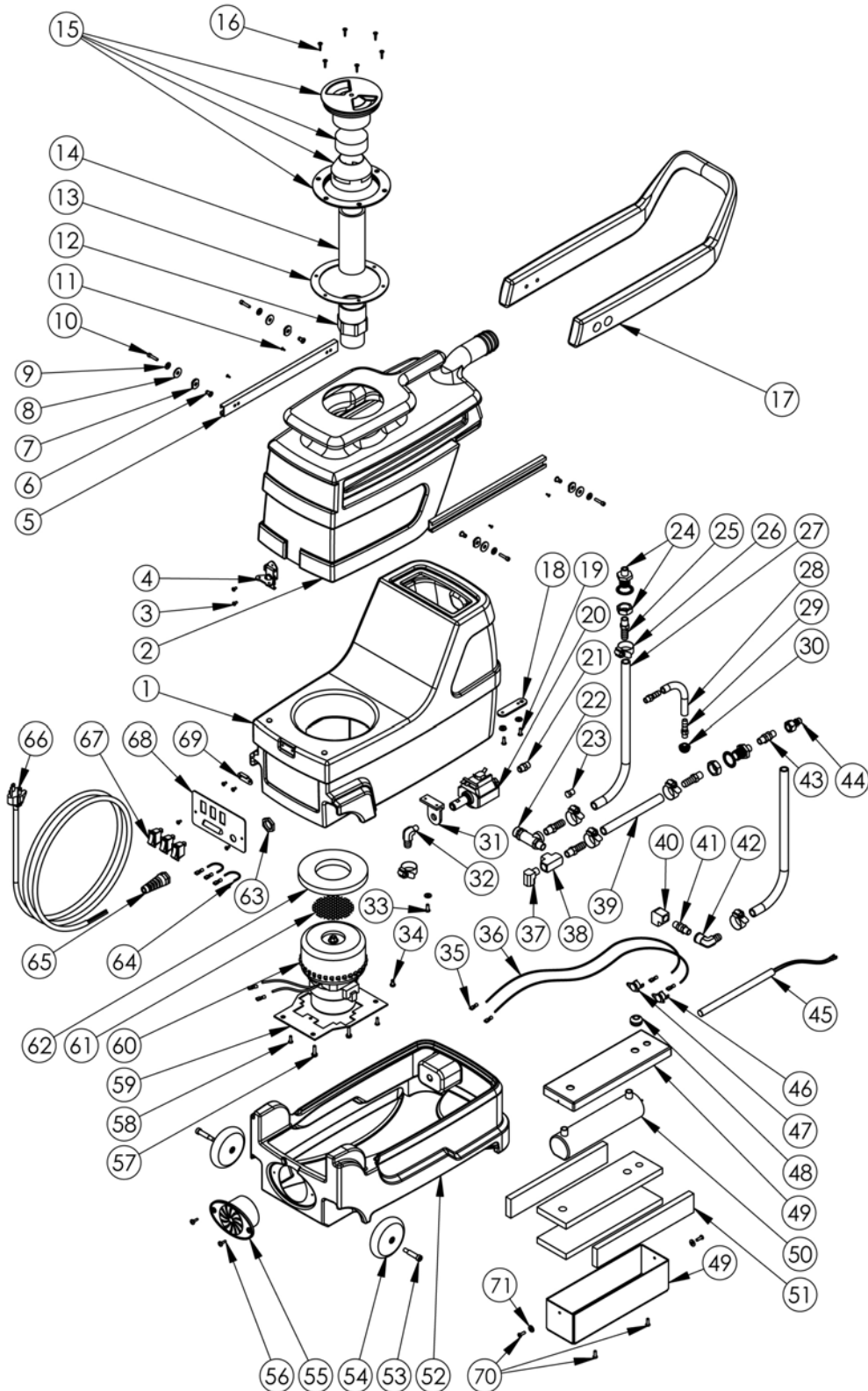



CF-3-H CleanFreak Spotter

3-Gallon Carpet Spot Extractor
with In-Line Heater
100 CFM / 804 Watt Motor

MACHINE PARTS LIST

Drawing No.	Item ID	Item Description	Qty. Needed
1	SP-3-ST-BLK	Black 3-Gallon Solution Tank	1.00
2	SP-3-RT-BLK	Black 3-Gallon Recovery Tank	1.00
3	10-0383	6-32 x 1/4" Phil Pan Screw	6.00
4	10-0400-D	Latch for Sniper	1.00
5	10-0412	C-Channel for Spotter Handle	2.00
6	10-0414	Rivet for Spotter Handle	4.00
7	10-0384	.125 Thick Nylon Washer	4.00
8	10-0385	.06 Thick Nylon Washer	4.00
9	10-0074	Flat Washer #8 SAE	11.00
10	10-0216	Allen Head Screw for Backpack	4.00
11	10-0379	8-32 x 3/8" Screw	4.00
12	10-0405	1-1/2" PVC SCH40 Slip Thread	1.00
13	10-0302-A	Hatch Cover Gasket for Spotter	1.00
14	10-0416-A	1-1/2" Black ABS Stand Pipe	1.00
15	10-0304	Spotter Cap and Float Assembly	1.00
16	10-0419	Screw for Spotter Hatch	6.00
17	SP-3-HS-BLK	Black 3-Gallon Heater Skirt	1.00
18	10-0831	S/R Bracket for Sniper	1.00
19	10-0832	S/R Strap Bolts	2.00
20	10-0300	55 psi Pump for Spotter	1.00
21	10-0403-M	1/8" Brass Male Nipple	1.00
22	10-0901	175 psi Relief Valve for Heater	1.00
23	10-0510	1/8" Brass Plug	1.00
24	80-0017	Bulk Head fitting for Sniper	2.00
25	80-0024-B	1/4 MPT x 3/8 Barb	4.00
26	10-0826	3/4" Hose Clamp for Sniper	6.00
27	10-0843	3/8" Black Hose for Sniper	1.00
28	10-0434	Threaded Hose for Spotter	1.00
29	10-0407	1/8" Strait Nylon Barb NPT	2.00
30	10-0845-2	1/8" Strainer for Spotter	1.00
31	10-0301	L Bracket for Spotter	1.00
32	10-0828	90 Degree Brass Fitting for Sniper	1.00
33	10-0022	Shoulder and Waist Belt Screw	3.00
34	10-0017	Deflector Screw	1.00
35	T-C-011	Female Terminal Connector	
36	T-WPUR	Purple Wire	
37	80-0011-2	90 Degree Street Elbow	1.00
38	80-0010	1/4" Brass Tee	1.00
39	10-0843	3/8" Black Hose for Sniper	1.00
40	10-0852	1/4" 90 Degree Brass Elbow	1.00
41	80-0101-M	1/4" Male Check Valve	1.00
42	80-0014	3/8" B x 1/4" F 90 Degree	1.00
43	10-0479	1/4" Male Close Nipple	1.00
44	10-0870	1/4" Male QD	1.00
45	10-1500-B	Heater Element 600 Watt	1.00
46	10-0814	Senor for Sniper Heater	1.00
47	10-0814-B	Manual Sensor for Heater	1.00
48	10-0907	Strain Relief for Tube Heater	1.00
49	10-0906	Box for Tubular Heater	1.00
50	10-0900	Heater Body Tubular	1.00
51	10-0801-G	Pipe Wrap Insulation for Heater	1.00
52	SP-3-H-ORA-1	3-Gallon Spotter Orange Handle	1.00
53	10-0387	5/16" x 1" Spotter Wheel Bolt	2.00
54	10-0303	Roller Blade Wheel for Spotter	2.00
55	10-0822	Exhaust Grate for Sniper	2.00
56	10-0419-A	Screw for Sniper Hatch	2.00
57	10-0014	Motor Screw	2.00
58	10-0380	10-32 x 3/8" Screw	2.00
59	10-1024	Motor Mount Plate for Spotter	1.00
60	10-0354	3 Gallon Spotter Motor	1.00
61	10-0386	Stamped Motor Screen	1.00
63	10-1030	Spotter Motor Gasket	1.00
64	10-0027-A	Strain Relief Nut	1.00
65	T-WBLA	Black Wire	
65	10-0027	Pigtail Strain Relief	1.00
66	10-0448	20-Foot Spotter/Air Mover Cord	1.00
67	10-0025	On/Off Switch	3.00
68	10-1026	Switch Plate for 3-Gallon w/ Heat	1.00
69	10-0400-C	Keeper Latch for Sniper	1.00
70	80-0022-A	Screw for 500 psi Panel	2.00
71	10-0204	Motor Mount Back-Up Washer	2.00



CF-3-H CleanFreak Spotter

3-Gallon Carpet Spot Extractor
with In-Line Heater
100 CFM / 804 Watt Motor

HOSES AND HAND TOOL SCHEMATIC DRAWING AND PARTS LIST

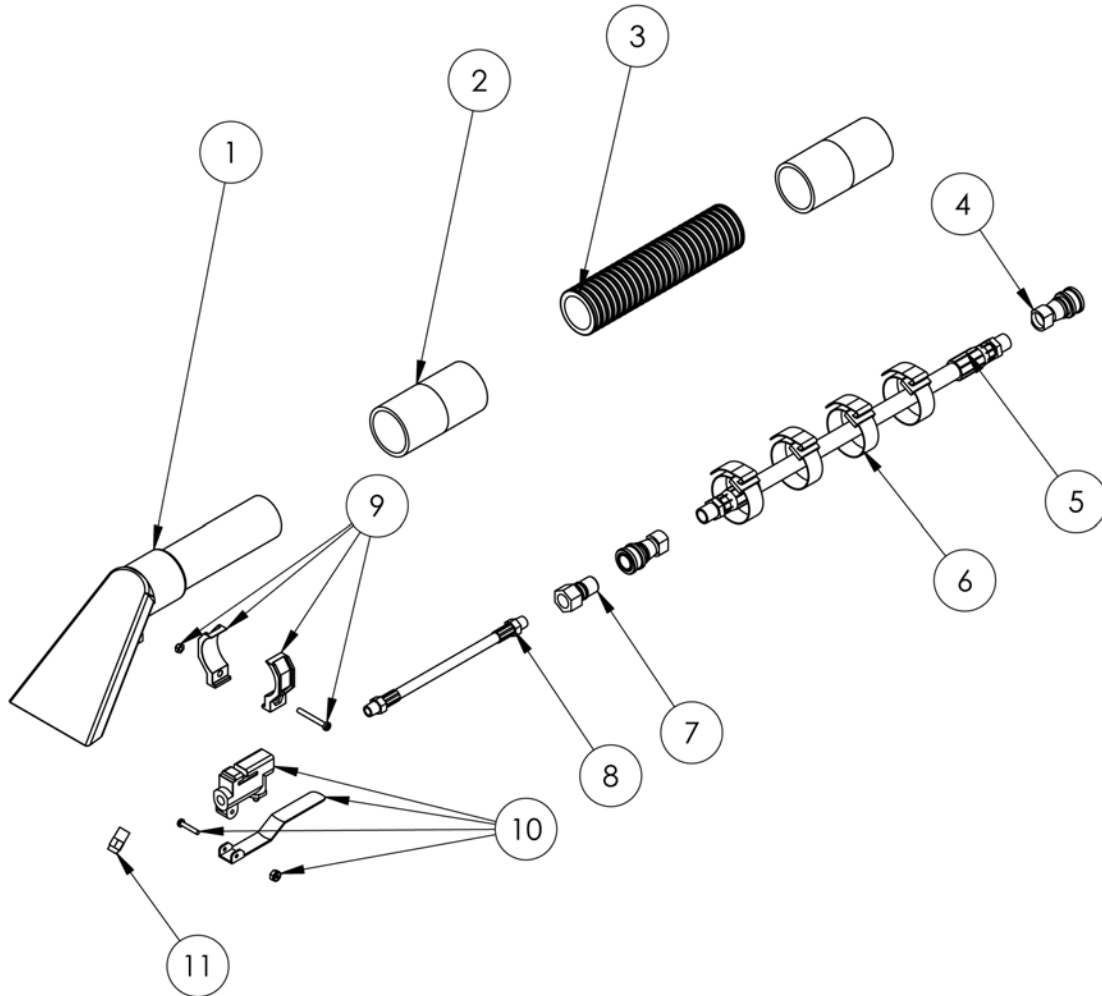

Drawing No.	Item ID	Item Description	Qty. Needed
1	10-0501	4" Stainless Steel Upholstery Tool	1.00
2	10-0463	Black Slip Hose Cuff - Spotter	2.00
3	50-1008	15-Foot Vacuum Hose 1-1/4"	1.00
4	10-0868	1/4" Female QD for Sniper	1.00
5	80-8007	1/4" x 15-Foot Extractor Hose	1.00
6	10-0388	Velcro Strap	1.00
7	10-0870	1/4" Male QD	1.00
8	10-0507	8" Black Hose for Stainless Steel Hand Tool	1.00
9	10-0506	Valve Clamp for Stainless Steel Hand Tool	1.00
10	10-0504	Valve for Stainless Steel Hand Tool	1.00
11	10-0502	Jet for Stainless Steel Hand Tool	1.00



CF-3-H CleanFreak Spotter

3-Gallon Carpet Spot Extractor
with In-Line Heater
100 CFM / 804 Watt Motor

CleanFreak

P.O. Box 569

Wausau, WI 54402

Toll Free: 888-722-5508

Local: 920-882-8453

Fax: 920-380-0878

www.CleanFreak.com

Model # _____

Serial # _____

Distributor Name: _____

Distributor Phone #: _____

Date of Purchase: _____

NOTES: