



SEMI-AUTO SCRUBBERS

www.usviper.com

OWNERS MANUAL

IMPORTANT: READ OWNERS MANUAL CAREFULLY

Please fill out & return your warranty card!

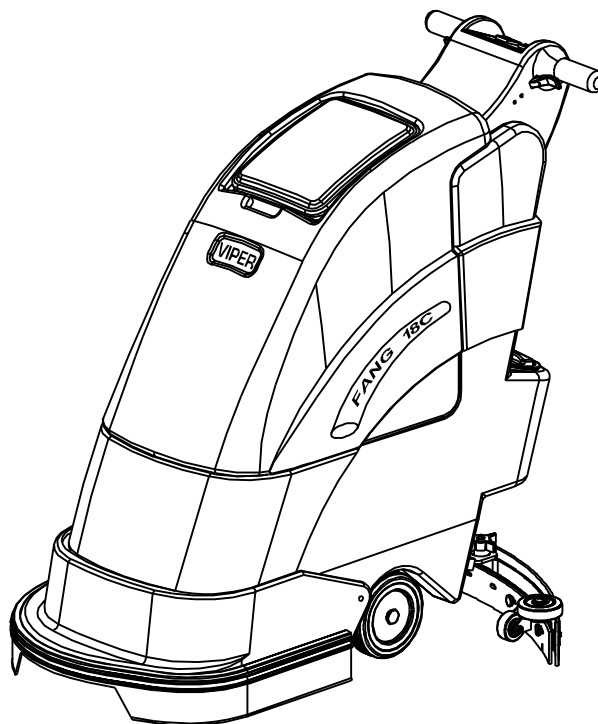

MODEL# FANG 18C

SERIAL# _____

**VIPER NORTH AMERICA
P.O. BOX 104
HAMILTON, MI 49419**

**(866) 418-4737
(866) 41 - VIPER**

**VIPER ...exceptional
value**

**REV.03(08-07)
80189**



CONGRATULATIONS on your purchase of a Viper product, and welcome to the V.I.P family. We appreciate your business and will do everything in our power to keep you happy with your purchase for many years to come.

As part of the V.I.P family, you are entitled to the best protection by one of the most comprehensive warranties in the industry.

Thank-you for purchasing Viper products!

TABLE OF CONTENTS

SAFETY PRECAUTIONS	1
MACHINE OPERATION	2-5
TECHNICAL SPECIFICATIONS	6
PARTS LIST	7-15
WIRING DIAGRAM	16



SAFETY PRECAUTIONS

This machine is intended for commercial use. It is constructed for use in an indoor environment and is not intended for any other use. Use only with recommended accessories.

All operators shall read, understand and exercise the following safety precautions:

1) DO NOT OPERATE MACHINE:

- Unless trained and authorized.
- Unless you have read and understand the operators manual.
- In flammable or explosive areas.
- If not in proper operating condition.
- In outdoor areas.

2) BEFORE OPERATING MACHINE:

- Make sure all safety devices are in place and operate properly.

3) WHEN USING MACHINE:

- Follow all safety guidelines.
- Report and fix any damage to machine prior to operating it.

4) BEFORE LEAVING OR SERVICING MACHINE:

- Stop machine on level ground.
- Turn machine off. Unplug cord from outlet.

5) WHEN SERVICING MACHINE:

- Read operators manual thoroughly prior to operating or servicing this machine.
- Turn machine off. Unplug cord from outlet.
- Use manufacturer supplied or approved replacement parts.

WARNING

: Flammable materials can cause an explosion or fire. Do not use flammable materials in tanks.

WARNING

: Flammable materials or reactive metals can cause explosion or fire. Do not pick up.

MACHINE SET UP & INSTALLATION

UNPACK MACHINE

Be sure and check packing carton for any damage. Immediately report any damage to carrier. Be careful not to let machine vibrate while carrying. Check contents of package to ensure that the following items are included: Machine, squeegee assembly, brush and pad driver.

MACHINE SET UP

PRE-OPERATION CHECKS

1. Sweep the outside of the machine.
2. Make sure the voltage of machine conform to local voltage. (China. 220-230V, 50Hz)
3. Check that squeegee is properly installed.
4. Check that brush / pad is properly installed.
5. Bumper doesn't touch the floor directly. The gap between the bumper and the floor surface can be adjusted by adjusting sliding plate.
6. The forward speed of machine can be controlled by turning the butterfly nut. Turn the nut clockwise to speed up machine. or turn the nut anticlockwise to slow down machine.
7. Make sure the working surface can support the machine weight, the gradient of the floor can't exceed the limit that machine allow.

INSTALLING PAD DRIVER OR BRUSH

1. Unplug machine.
2. Tilt the machine backwards, line up the drive pulley hub with the hole of brush or pad driver, make sure the three blocks are fitted into the three slots of drive pulley.
3. If a pad driver is being used, the appropriate pad should be attached to the pad driver first.
4. Plug power cord into a grounded outlet, switch on the brush motor and then pull the operating triggers gently to mount the pad driver or brush automatically.

INSTALLING THE SQUEEGEE

1. Loosen the two knobs on the squeegee and slide the squeegee into the slots at the rear of

the squeegee bracket. (the wheels on the squeegee point to the back)

2. Tighten the knobs securely.

FILLING THE SOLUTION TANK

1. The fill port is located at the rear of machine.
2. Fill solution tank with water. (water temperature should not exceed 140° F) The clear tube in the back left of the machine has gallon markers to help determine the water level in the solution tank

WARNING

: Do not put any flammable materials into solution tank. This can cause an explosion or a fire. Only use recommended cleaning chemicals. Contact your janitorial supply distributor for recommendations on proper chemicals.

MACHINE OPERATION

WARNING

: Do not operate machine unless you have read and understand this manual.

1. Adjust control housing to a comfortable operating height by squeezing together the two thumb levers directly underneath the housing.
2. Lower squeegee assembly to the floor.
3. Turn brush motor switch to "on" position.
4. Turn vacuum motor switch to "on" position.
5. Rotate the ball valve of solution tank to horizontal position. Solution will not begin to flow until the operating triggers are pulled.
6. To begin scrubbing, pull on one or both of the red operating triggers, when these triggers are pulled, the brush will begin to spin and the solution will begin to flow.
7. Begin scrubbing by moving the machine forward.

HINT

: Do not keep the machine in the same position with the pad / brush spinning, or you could cause damage to the floor.

8. Adjust solution flow by adjusting the position of ball valve knob.

WHILE OPERATING MACHINE

1. Occasionally look through the clear recovery tank lid to see if there is any foam build-up. If excessive foam is found, add defoamer to the recovery tank.

WARNING : Foam must not enter the float shut-off screen, or damage can occur to the vacuum motor. Foam will not activate the machines float shut-off device.

2. Occasionally view the clear tube at the back left of the machine to check the amount of cleaning solution that is left in the machine.

If the squeegee assembly leaves streaks on the floor, raise the squeegee off the floor and wipe the blades down with a damp cloth.

WARNING : Do not use your fingers to wipe or remove debris from the blades, as injury may occur.

When the solution tank runs empty, turn off the brush switch and ball valve of solution tank. Keep the squeegee down and continue to vacuum until all the dirty water is picked up.

TANK DRAINING

1. Turn the switches on the control panel to "off" position.
2. Raise the squeegee, transport machine to approved area for draining tank(s).

DRAINING THE RECOVERY (DIRTY) TANK

HINT : Any time scrubbing is completed, or when refilling solution tank, the recovery tank should be drained and cleaned.

WARNING : If the recovery tank is not drained when the solution tank has been refilled, foam or water may enter the float shut-off mechanism and cause damage to the vacuum motor.

1. Remove the drain hose from the holder, and place the drain hose over the floor drain. Twist off the drain hose plug to begin the draining process.
2. Clean the recovery tank after every use. Use a fresh water hose to rinse out the recovery tank. Be careful not to spray water into the float shut-off mechanism.

HINT : If you are storing the machine for any period of time, always leave the clear recovery tank lid off the tank so the tank can dry completely and smell fresh.

DRAINING THE SOLUTION (CLEAN) TANK

HINT : Any time scrubbing operation is completed, the solution tank should be drained and cleaned.

1. Pull down on the clear tube (back left of the machine) to remove it from the hose barb. This will allow the solution to flow freely into a bucket or floor drain.
2. Rinse the solution tank with clean water after every use. This will help prevent chemical buildup and clogging of the solution lines.
3. Once tank is rinsed, flushed and drained, reconnect the clear tube to the hose barb. Be sure the tube is pushed all the way up on the hose barb.

PREVENTATIVE MAINTENANCE

WARNING : Before performing any maintenance on the machine, be sure that the power is turned off.

WARNING : Repairs are to be completed by Authorized Service Centers only. Any repairs completed by unauthorized persons will void the warranty.

1. Remove pad driver / brush and clean with approved cleaner.
2. Drain recovery and solution tanks completely and rinse out with clean water. Visually check the recovery tank for debris and clean out as necessary.
3. Raise squeegee assembly off floor and wipe

it down with a damp towel. Be sure to store the squeegee in the up position.

4. Remove the float shut-off assembly and rinse it out with clean water.
5. Clean machine with an approved cleaner and a damp towel. Don't spray water to clean the outside of machine to avoid damage to motor and wiring.
6. Unplug vacuum motor from power source and hose cuff & remove the drain hose from the holder prior to removing the recovery tank when performing maintenance.

VACUUM MOTOR MAINTENANCE

1. Contact your local Viper Distributor for any motor maintenance.
2. Check the vacuum motor brushes every 250 hours, Replace the brushes when they are worn to a length of 10mm or less.

MACHINE STORAGE

1. Always store the machine indoors.
2. Always store the machine in a dry area.
3. Always take off the pad driver / brush
4. Always store the machine with the squeegee assembly raised off the floor.
5. If storing in an area which may reach freezing temperatures, be sure to drain all fluids from the machine prior to storage. Any damage caused by freezing temperatures will not be covered by the warranty.
6. Drain the recovery tank and remove the clear on the top of the recovery tank so that it can "breathe" during storage.
7. Drain the solution tank of all fluid.

BASIC TROUBLESHOOTING

PROBLEM	CAUSE	SOLUTION
No Power	The wiring not connected correctly or bad wiring	Check the wiring or contact Viper Distributor
	Bad brush motor	Contact Viper Distributor
	Carbon brushes worn out	Contact Viper Distributor
Vacuum motor does not run	The wiring not connected correctly or bad wiring	Check the wiring or contact Viper Distributor
	Bad vacuum motor	Contact Viper Distributor
	Carbon brushes worn out	Contact Viper Distributor
Little or no solution flow	Bad ball valve	Contact Viper Distributor
	Bad solution valve	Contact Viper Distributor
	Ball valve position in need of adjustment	When ball valve is in horizontal position. The amount of solution flow is maximum.
Poor water pick up	Squeegee clogged	Clean debris off squeegee with damp towel
	Squeegee blades worn	Install new squeegee blades
	Squeegee not mounted correctly	Confirm that the squeegee assembly is securely fastened to the machine and not loose fitting
	Vacuum hoses have a hole or are loose	Check hose connections and make sure they are firm. Replace hose if damaged.
	Vacuum hose may be clogged	Check hose for debris and remove any clog.
	Drain hose stopper is loose	Tighten drain plug.
	Vacuum motor is loose	Tighten vac motor mounting screws. Do not over tighten or damage will occur.
	Recovery tank lid is loose	Confirm the clear recovery tank lid is securely in place.
	Recovery tank is full	Drain recovery tank
	Float shut off is clogged	Remove float shut off from inside recovery tank and remove any debris

Technical Specifications:

Working Width	450mm
Squeegee Width	750mm
Efficiency	1100m ² /h
Brush Dia.	450mm
Brush Speed	255rpm
Max Pad Pressure	30Kg
Brush Motor	110-115V, 750W
Vacuum Motor	110-115V,650W
Solution Tank Capacity	30L
Recovery Tank Capacity	41L
Machine Weight	68Kg
Machine Length	1100mm
Machine Height	970mm
Machine Width	545mm
Cable Length	25M
Max Gradient	2%
Type of Drive	Semi-Automatization
Noise Level	70dB
Working Vacuum	155mbar

PARTS LIST

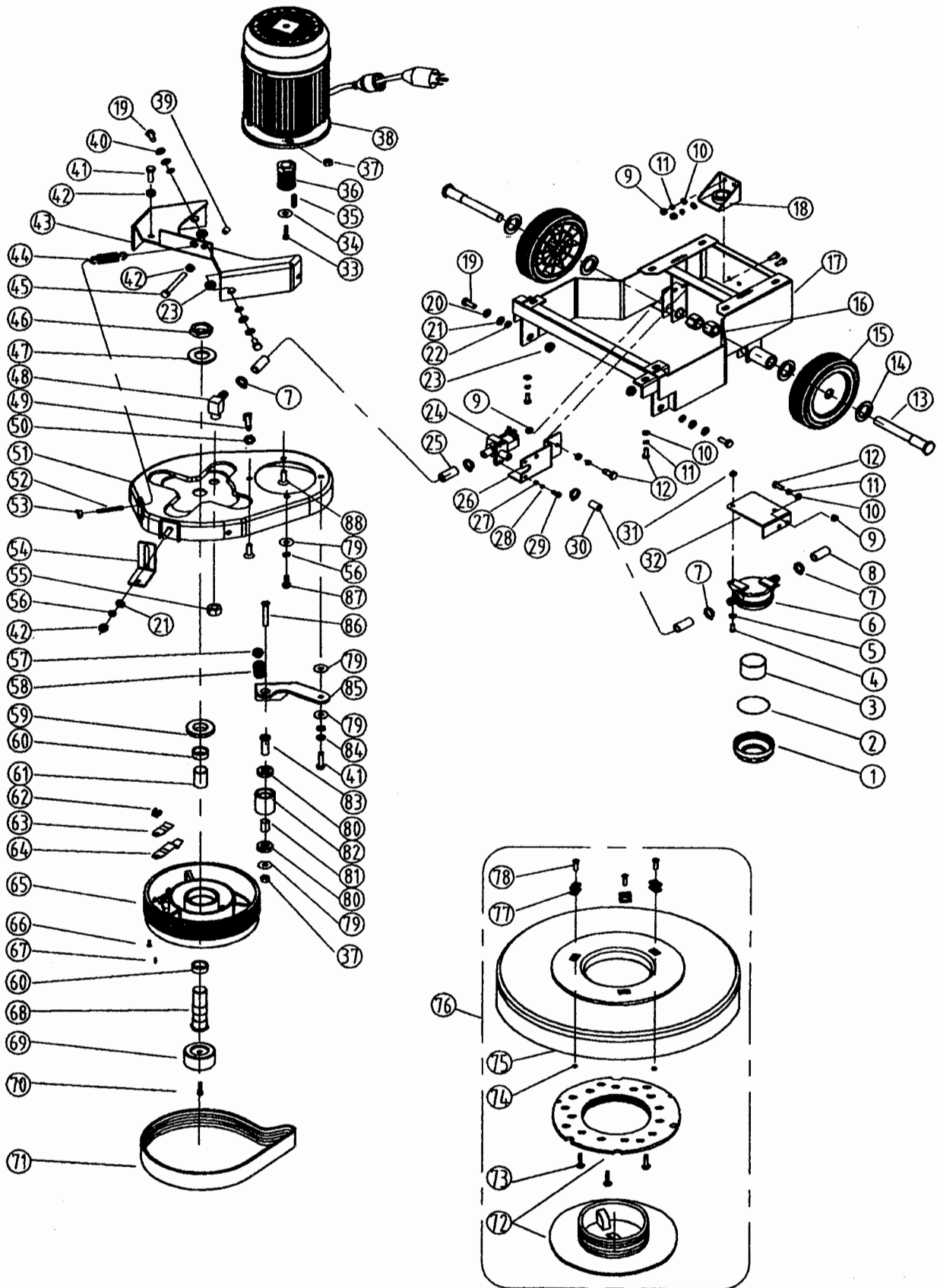

DIA NO.	PART NUMBER	DESCRIPTION	NO. REQ'D
1	VF80111	CLEAR DOME, FILTER	1
2	VF82139	"O"RING	1
3	VF80113	FILTER	1
4	VV20501	PH SCREW, M5X14 SST	2
5	WV13654	WASHER, Ø5 SST	2
6	VF80112	MOUNTING BASE, FILTER	1
7	VF82090	CLAMP, HOSE	5
8	VF80349	HOSE, INLET, FILTER	1
9	VF13521	NUT, M6	12
10	VF13533	WASHER, Ø6	12
11	WV13607	WASHER, LOCK, Ø6	12
12	VF13495	SCREW, M6X16	12
13	VF80123	AXLE, WHEEL	2
14	VF80117	WASHER, WHEEL	4
15	VF80115	WHEEL, 6"	2
16	VF14257	NUT, NYLON INSERT, M16	2
17	VF80110	CHASSIS	1
18	VF80109	CONNECTOR	1
19	WV13604	SCREW HEX, M8X20	4
20	VF14313	WASHER, INTERNAL TOOTH, Ø8	2
21	VF13514A	WASHER, PLAIN, Ø8	5
22	VF80130	WASHER, Ø8	4
23	VF80132	BUSHING	4
24	VF80216A	SOLUTION VALVE 110V	1
25	VF80238	HOSE, OUTLET, VALVE	1
26	VF80119	MOUNTING FRAME, VALVE	1
27	VA13483	WASHER, PLAIN, Ø4	2
28	WV20291	WASHER, LOCK, Ø4	2
29	VA13473	PH SCREW, M4X16	2
30	VF80114	OUTLET FILTER	1
31	GT13022	NUT, NYLON INSERT, M5	2
32	VF80120	MOUNTING PLATE, FILTER	1
33	VV60220S1	HEX SOCKET SCREW, M6X15	1
34	VF80207	WASHER, PLAIN BRASS	1
35	VF80240	KEY	1
36	VF80220	DRIVING PULLEY	1
37	VF13503	NUT, NYLON INSERT, M8	5
38	YCQ35000A	MOTOR 110V	1
39	VF80241	GASKET	1
40	VF14314	WASHER, EXTERNAL TOOTH, Ø8	2
41	GT13018	BOLT, M8X30	2
42	VF13513	NUT, M8	3
43	VF80206	SUPPORTING SHELF	1
44	VF80237	SPRING	1
45	VF14114	BOLT, M8X55	1

DIA NO.	PART NUMBER	DESCRIPTION	NO. REQ'D
46	VF80222	THIN NUT	1
47	VF14315	WASHER, PLAIN, Ø24	1
48	VF81403	BARB HOSE 90° DEG	1
49	VF14255	SET SCREW, M12X65	1
50	VF14057A	NUT,M12	1
51	VF80201	FRAME	1
52	VF80225	BOLT	1
53	VF14101	NUT,BUTTERFLY,M6	1
54	VF80203	SLIDING PLATE	1
55	VF80213	NUT,BRASS	1
56	VF13519	WASHER,LOCK,Ø8	2
57	VF80235	SPACER	1
58	VF80232	SPRING	1
59	VF80223	SPACER	1
60	VF999827	BEARING 6205	1
61	VF80221	BIG,SPACER	1
62	VF80229	NUT	1
63	VF80227	CLIP	1
64	VF80228	CLIP,BRUSH	1
65	VF80205	DRIVEN PULLEY	1
66	VF14223	FH SCREW, M6X25	1
67	VF14254	SET SCREW HEX SOCKET, M5X8	1
68	VF80219	SHAFT DRIVEN PULLEY	1
69	VF80233	GASKET	1
70	GT13060	HEX SOCKET SCRW, M6X30	1
71	VF80242	BELT	1
72	VF99003A	BIG MOUTH	1
73	VF14400	ST4.2X13	3
74	VF13502	NUT NYLON INSERT,M6	3
75	VF80212	PAD HOLDER	1
76	VF80212A	PAD HOLDER ASSY	1
77	VF80218	BLOCK	3
78	VF14225A	FH SCREW, M6X40	3
79	VF13535	WASHER, PLAIN, Ø8XØ20X2	4
80	VF999821	BEARING 6002LU	2
81	VF80209	SMALL SPACER	1
82	VF80215	TENSION WHEEL	1
83	VF80214	BUSHING BEARING	1
84	VF14312	WAVING WASHER, Ø8	2
85	VF80208	ROD, TENSION WHEEL	1
86	GT13066	HEX SOCKET SCREW, M8X55	1
87	VV13657	BOLT, M8X25	1
88	GT13067	HEX SOCKET SCREW, M8X25	2

PARTS LIST

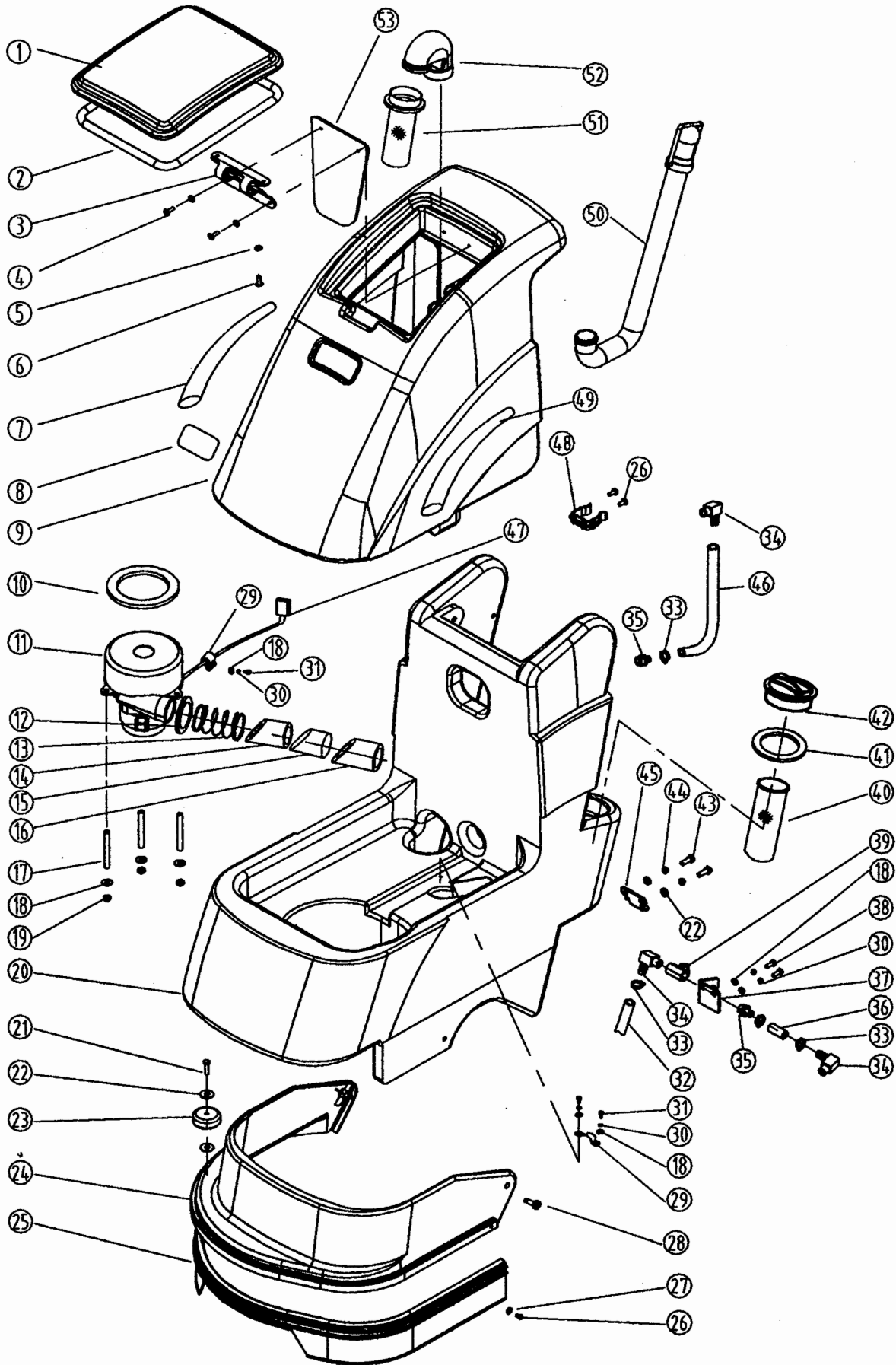

DIA NO.	PART NUMBER	DESCRIPTION	NO. REQ'D
1	VF82010	CLEAR COVER,RECOVERY TANK	1
2	VF82010B	GASKET,CLEAR DOME	1
3	VF82010A	RUBBER HINGE	1
4	VF13491	PH SCREW,M4X12	2
5	VA13483	WASHER,PLAIN,Ø4	4
6	VA13477	ST4.2X16	2
7	VF80343A	MODEL DECAL,RIGHT	1
8	VF80326A	VIPER LOGO	1
9	VF80302	RECOVERY TANK	1
10	VF81503	GASKET, MOTOR	1
11	VV67153	VAC MOTOR 110V	1
12	VV10116	TIE	3
13	VF80346	SPRING	1
14	VF80356	SPONGE,EXHAUST	1
15	VF80358	PLASTIC COVER	1
16	VF80357	HEAT RESISTANCE COVER	1
17	VF82310	BOLT	3
18	VF13533	WASHER,PLAIN,Ø6	7
19	VF13502	NUT,NYLON INSERT, M6	3
20	VF80301	SOLUTION TANK	1
21	VF14236	BOLT, M8X40	1
22	VF13514A	WASHER,PLAIN,Ø8	4
23	VF82013	WHEEL,3"	1
24	VF80308	SKIET	1
25	VF80319A	BUMPER	1
26	VV20501	PH SCREW,M5X14	4
27	VV13654	WASHER,PLAIN,Ø5XØ9.5X0.8	2
28	VF80355	SHOULDER SCREW,Ø10X16XM8	2
29	VV50712	CLAMP	1
30	VV13607	WASHER,LOCK,Ø6	4
31	VF14200	PH SCREW,M6X16	4
32	VF80349	HOSE,OUTLET,BALL VALVE	1
33	VF82090	CLAMP,HOSE	4
34	VF81403	BARB,HOSE BRASS	2
35	VF80313	BARB,HOSE	3
36	VF80348	HOSE	1
37	VF80321	MOUNTING PLATE,BALL VALVE	1
38	VF13495	BOLT, M6X16	2
39	VF80361	BALL VALVE	1
40	VF46454	FILTER	1
41	VF80306	SEAL	1
42	VF80304	FILL	1
43	VV13604	BOLT,M8X20	2
44	VF13519	WASHER,LOCK,Ø8	2
45	VF80359	CLAMP,SQUEEGEE	1
46	VF80347	SOLUTION HOSE	1
47	VF45117C	CORD	1
48	GV70034	CLAMP DRAIN HOSE	1
49	VF80342A	MODEL LABEL,LEFT	1
50	VA93208A	DRAIN HOSE	1
51	VF81504	FLOAT,SHUTOFF	1
52	VV67305	BEND	1
53	VF80345	SCREEN	1

PARTS LIST

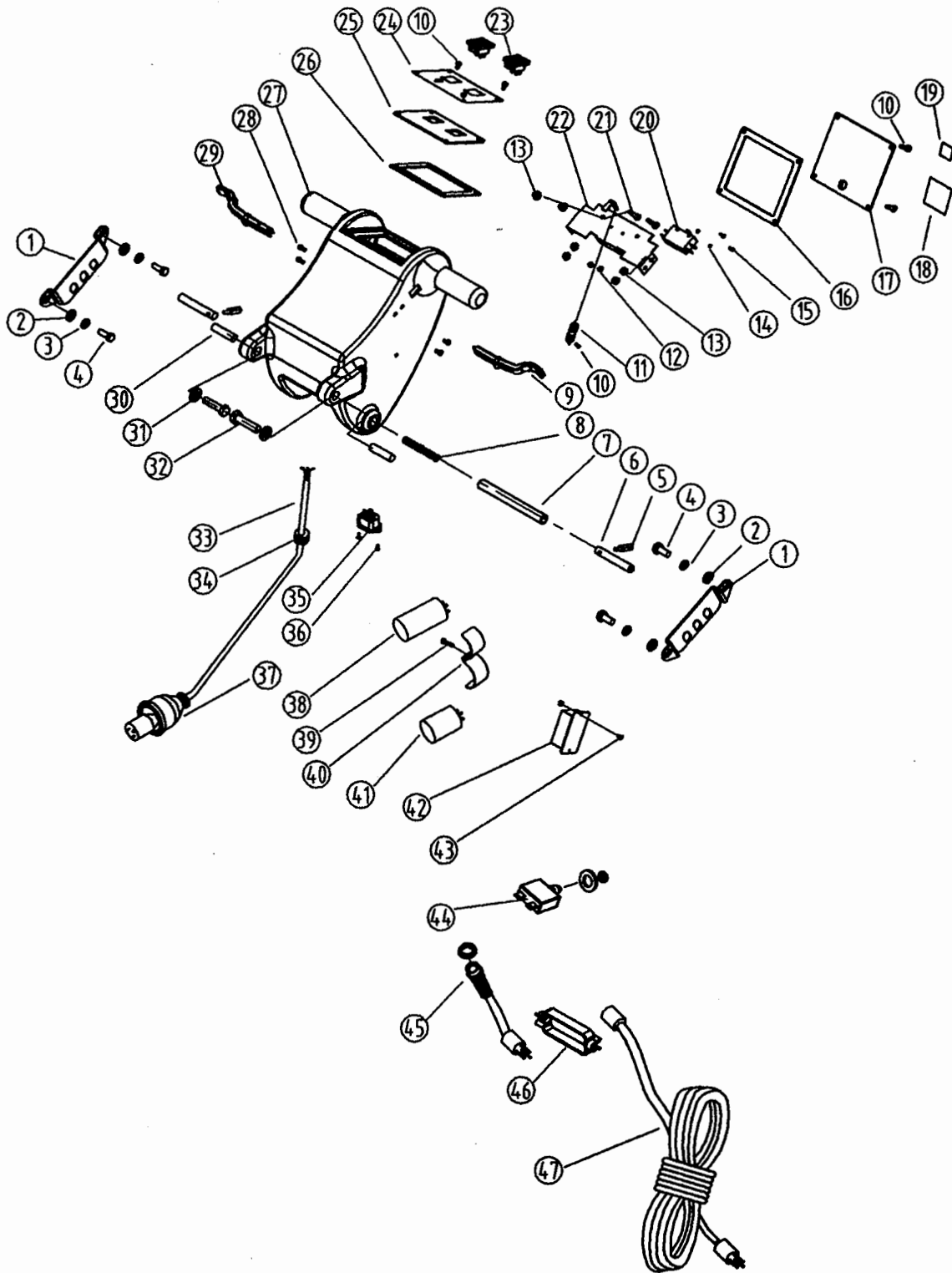

DIA NO.	PART NUMBER	DESCRIPTION	NO. REQ'D
1	VF81408	ADJUSTING PLATE	2
2	VF13535	WASHER,PLAIN,Ø8	3
3	VF13519	WASHER,LOCK,Ø8	4
4	VV13604	BOLT,M8X20	4
5	VF81710	ADJUSTING SCREW	2
6	VF80322	PIN, HANDLE LOCK	2
7	VF80323	TUBE, HANDLE, ADJUSTMENT	1
8	VF81716	SPRING	1
9	VF80317	LEVER,SWITCH,LEFT	1
10	VV13650	PH SCREW, M4X10	9
11	VF81712	SPRING	1
12	VV13652	NUT,NYLON INSERT,M3	2
13	VF13502	NUT,NYLON INSERT,M6	6
14	VF13511	WASHER,PLAIN,Ø3	2
15	VF14212	PH SCREW,M3X25	2
16	VF80335	GASKET,REAR COVER	1
17	VF80310	REAR COVER	1
18	VF80331	WARNING LABEL	1
19	VF80329	DECAL,SERIAL	1
20	VF99023	SWITCH	1
21	VF81711	SHOULDER SCREW,Ø8X20XM6	2
22	VF80307	MOUNTING FRAME,SWITCH	1
23	VA91346	SWITCH	1
24	VF80324	DECAL,SWITCH	1
25	VF80305	SWITCH PANEL	1
26	VF80333	GASKET,PANEL	1
27	VF80303	CONTROL HOUSING	1
28	VF14200	PH SCREW,M6X16	4
29	VF80318	LEVER,SWITCH,RIGHT	1
30	VF81713	BUSHING	1
31	VF13537	WASHING,PLAIN,Ø10	1
32	VF14237	BOLT,M10X70	1
33	VF45120	CORD	1
34	VV30182	BUSHING,CORD	1
35	VF51141	RECEPTACLE	1
36	GT13065	ST3X12	1
37	AS41902	PLUG PROTECTOR, FEMALE	1
38	VV30142	RUN CAPACITOR,40 µ F/375V	1
39	GT13027	PH SCREW, M5X45	1
40	VF80365	CLAMP	1
41	VF999805	START CAPACITOR, 380-400 µ F/150V	1
42	VF80366	REGULATION SPEED ELEMENT	1
43	VV13616	PH SCREW, M3X16	1
44	VF99017	BRUSH CIRCUIT BREAKER	1
45	VF99008B	STRAIN RELIEF	1
46	VV67105	CONNECTOR,CORD	1
47	VF80362C	POWER CORD	1

PARTS LIST

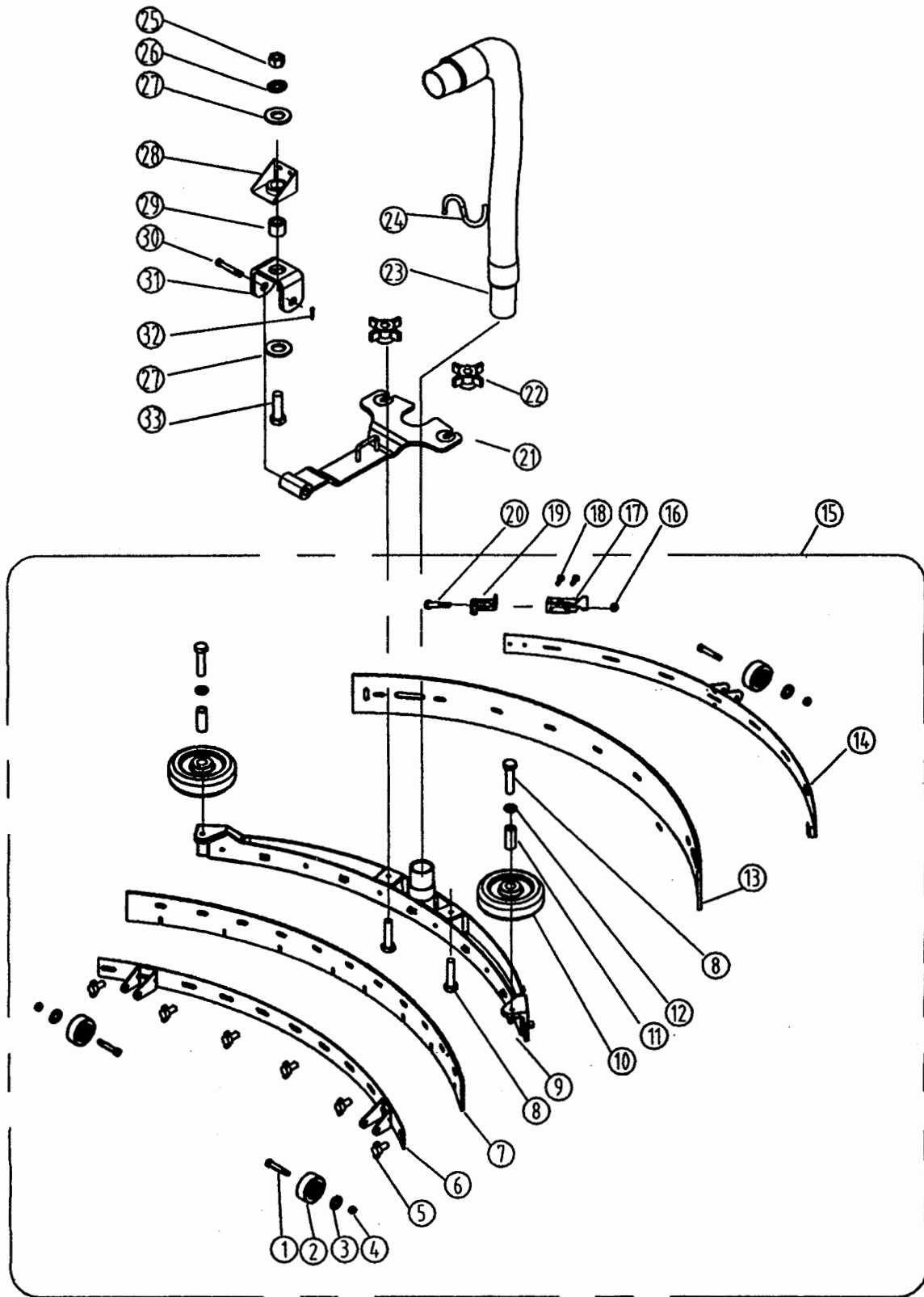

Wiring Diagram

